



# Arcata 2826/2806 CIP-D

*User Guide*

This document is the copyright of Teltronics, Inc. and is intended for exclusive use of Teltronics customers. All rights are reserved. Information in this document is subject to change without notice. Companies, names, and data used in examples herein are fictitious unless otherwise noted. No part of this document may be reproduced, modified, republished, distributed, displayed or transmitted in any form or by any means, electronic or mechanical, for any purpose, without the express written permission of Teltronics, Inc.

© 2010 Teltronics, Inc. All rights reserved.

The material in this document has been carefully reviewed; however, Teltronics, Inc. neither guarantees nor represents that this document is free of all errors or omissions and reserves the right to make corrections, changes, updates, or revisions to the information contained herein at any time.

The Teltronics and Cerato brand or product names are trademarks/servicemarks of and the exclusive property of Teltronics, Inc. of Sarasota, FL.

Other than those trademarks/servicemarks held by Teltronics, Inc., any other brand and product names referenced in this manual are trademarks or registered trademarks of their respective holders and are used here for informational purposes only.

Part Number: 610-0000-0847 Rev B

Teltronics, Inc.  
2511 Corporate Way  
Palmetto Florida 34221-8478 USA

Visit our web site at [www.teltronics.com](http://www.teltronics.com)

# TABLE OF CONTENTS

<b>SOFTWARE LICENSE</b> .....	<b>v</b>
<b>SUMMARY OF CHANGES</b> .....	<b>xvii</b>
<b>SAFETY INSTRUCTIONS</b> .....	<b>xix</b>
<b>INTRODUCTION</b> .....	<b>1</b>
28xx CIP-D Features .....	3
Components .....	7
Quick Tour of the 28xx CIP-D .....	10
<b>PHONE SETUP</b> .....	<b>15</b>
<b>USING THE ARCATA PHONE</b> .....	<b>27</b>
ACCOUNT CODE CALLING .....	28
ANSWERING CALLS .....	29
APPOINTMENT REMINDER .....	31
CALLBACK .....	33

---

CANCEL/HANG UP .....	35
CONFERENCE .....	36
CONTACT LIST .....	37
DIAL .....	40
DIRECTORY .....	42
FEATURES .....	43
FORWARD .....	44
HEADSET .....	46
HISTORY .....	47
HOLD .....	50
INTERCOM (COM) CALLING .....	51
LINE KEY LABELS .....	53
MENU .....	54
MUTE .....	55
NAVIGATE .....	56
PAGE .....	57
PARK .....	59
PARK PICKUP .....	60
PICKUP (Group and Directed) .....	61
PRIVACY .....	63
REDIAL .....	64
RING TONES .....	66
SPEAKERPHONE .....	67
SPEED DIAL .....	68

---

TIME AND DATE .....	70
TRANSFER .....	71
VIEW EXTENSION .....	72
VOICE MAIL .....	74
VOLUME .....	75
WEB CONFIGURATION .....	76
<b>TROUBLESHOOTING.....</b>	<b>77</b>
<b>VIEWING PHONE SETTINGS.....</b>	<b>81</b>
<b>FCC REQUIREMENTS .....</b>	<b>85</b>
<b>ACCESS CODES AND AUDIBLE TONES.....</b>	<b>87</b>
Access Codes .....	88
Audible Tones .....	89
<b>Index .....</b>	<b>91</b>

---

This page intentionally blank

# SOFTWARE LICENSE

## TELTRONICS, INC. END USER LICENSE AGREEMENT (10.7.10)

NOTICE: BY DOWNLOADING, INSTALLING, COPYING, ACCESSING, CLICKING ON AN “ACCEPT” BUTTON, OR OTHERWISE USING THE PRODUCT, END USER AGREES TO THE TERMS OF THIS END USER LICENSE AGREEMENT. IF YOU ARE ACCEPTING THESE TERMS ON BEHALF OF THE END USER, YOU REPRESENT AND WARRANT THAT YOU ARE ACTING ON BEHALF OF THE END USER AND ARE AUTHORIZED TO ACCEPT THIS END USER LICENSE AGREEMENT ON THE END USER’S BEHALF AND THAT YOU HAVE THE FULL AUTHORITY TO BIND THE END USER TO THESE TERMS AND CONDITIONS (SUCH END USER BEING HEREIN REFERRED TO AS “YOU”). IF YOU DO NOT AGREE TO THESE TERMS AND CONDITIONS, DO NOT DOWNLOAD, INSTALL, COPY, ACCESS, OR USE THE PRODUCT; AND WITHIN THIRTY (30) DAYS OF DELIVERY OF THE PRODUCT RETURN THE UNUSED PRODUCT AND PROOF OF PURCHASE TO THE PARTY FROM WHOM YOU PAID THE PRODUCT PURCHASE PRICE AND LICENSE FEES FOR A REFUND, IF ANY OR SELECT THE “DO NOT ACCEPT” BUTTON. YOU AGREE THAT YOU HAVE READ, UNDERSTAND AND SHALL ABIDE BY THIS END USER LICENSE AGREEMENT AND YOU AGREE THAT THIS END USER LICENSE AGREEMENT IS ENFORCEABLE LIKE ANY WRITTEN NEGOTIATED AGREEMENT SIGNED BY YOU.

THE FOLLOWING TERMS AND CONDITIONS OF THIS END USER AGREEMENT AND SEPARATE AGREEMENT(S) INCORPORATED HEREIN BY REFERENCE (COLLECTIVELY, “AGREEMENT”) APPLIES TO

---

THE PRODUCTS DESCRIBED HEREIN AND FURNISHED TO YOU BY TELTRONICS OR ITS DISTRIBUTOR OR RESELLER. THE SOFTWARE IS NOT SOLD TO YOU, BUT IS THE PROPERTY OF TELTRONICS AND/OR ONE OR MORE OTHER THIRD PARTY LICENSORS PROTECTED BY COPYRIGHT LAWS AND INTERNATIONAL TREATY. ANY USE OF THE SOFTWARE IS GOVERNED BY THIS AGREEMENT. YOU AGREE THAT YOU ARE LICENSING THE SOFTWARE FOR YOUR END USE ONLY AND NOT FOR RESALE OR REDISTRIBUTION.

1. DEFINITIONS. "Product" means equipment, Software, product documentation and associated services furnished to You concerning the use and support of the Product. "Software" means software object code, application interfaces, documentation and any updates, revisions or modification thereto on magnetic tape, diskette, CD-ROM, semiconductor device or other memory device.

2. LICENSE. (a) With respect to all Software of Teltronics and/or its vendors or suppliers which may be furnished to You by Teltronics hereunder, You accept and agree to abide by all the license terms and conditions set forth herein and any other separate license agreements that are specific to, and included in document or shrink wrap form with the shipment of particular Software, or presented in electronic form (including click wrap form) during the loading or installation of such Software. In the event of any conflict between the license terms and conditions set forth herein and any such separate license agreements specific to any particular Software, the license agreements specific to such particular Software shall prevail with respect to such particular Software. All Software furnished hereunder shall be licensed only as set forth herein.

(b) Subject to your compliance with this Agreement including the license obligations pursuant to this Section , and your payment of the applicable license fees, Teltronics grants to You a personal, nontransferable, nonexclusive and revocable license to use the Software solely with the equipment sold to You by Teltronics or its distributor or reseller, or such other equipment as may be authorized by Teltronics to support such use of the Software for your



---

own business operation up to the number of concurrent devices and/or ports as may be authorized by Teltronics. You shall not copy the Software except that You are permitted to make one (1) copy of the Software, to the extent that it is made available in a form than is intended to be copied, only for backup purposes, provided that You shall include on such copy the same copyright notice and proprietary marking that appear on the original Software including diskette markings.

(c) You shall (i) not modify, translate, reverse engineer, reverse compile, decompile, recompile, disassemble, port, copy, download or attempt to derive the source code from the Software, and no license to the source code is provided herein; (ii) take all actions necessary to satisfy your obligations under these license provisions including the issuance of adequate instructions and monitoring of all appropriate personnel within your organization to ensure that such personnel satisfy these license obligations; and (iii) promptly return to Teltronics any magnetic tape, diskette, CD-ROM, semiconductor device or other memory device or system and/or Documentation, which has been replaced, modified or updated by Teltronics.

(d) The Software and all copies thereof shall at all times remain the sole and exclusive property of Teltronics or its third party vendors or suppliers, as applicable, and You shall have no title to or interest in such Software and copies thereof. You acknowledge that the Software constitutes valuable trade secrets of Teltronics and its third party vendors or suppliers. You agree to use the Software solely in accordance with license provisions herein and all the terms and conditions of this Agreement and to treat the Software as the confidential and proprietary information of Teltronics. If You sell or otherwise dispose of the media on which the Software is fixed, such Software must be erased or destroyed before any such sale or disposal so that the Software is no longer ascertainable from such media.

(e) If You sell or otherwise transfer or dispose of the equipment which supports the use of the Software in your business operation, or if You fail to comply with any of the terms of this Agreement, all of your rights hereunder to

---

possess and use the Software and all copies thereof shall immediately terminate and You agree to promptly return the Software and all copies thereof to Teltronics.

3. **PRODUCT CHARGES AND LICENSE FEES.** Product charges and license fees paid by You are paid in consideration of the rights granted under this Agreement.

4. **TERM.** The Agreement is effective upon your acceptance of its terms as herein provided or any use of the Products and shall continue until terminated. You may terminate this Agreement at any time by returning the Software and all copies thereof and extracts therefrom to Teltronics. Teltronics may terminate this Agreement upon the breach by You of any term of this Agreement, and Teltronics shall have the right to injunctive relief enjoining such acts or attempts constituting a breach (in addition to other legal remedies, all of which are non-exclusive). Upon such termination by Teltronics, You agree to promptly return to Teltronics the Software and all copies and extracts thereof. The following provision shall survive any termination of this Agreement: "Limited Warranty," "Limitation of Liability," "Governing Law, Venue and Jurisdiction," "Enforceability," "No Waiver," "Export Compliance," and "Entire Agreement."

5. **LIMITED WARRANTY.** The only warranty Teltronics provides with respect to any Product is the written Limited Warranty statement provided with the Product or, if no Limited Warranty statement is provided with the Product, the Limited Warranty Statement available at the following internet address: <http://www.Teltronics.com>.

**DISCLAIMER. EXCEPT AS SPECIFIED IN THE LIMITED WARRANTY STATEMENT SPECIFIED IN THE SECTION ABOVE, ALL EXPRESS OR IMPLIED CONDITIONS, REPRESENTATIONS OR WARRANTIES INCLUDING, WITHOUT LIMITATION, ANY IMPLIED WARRANTY OR CONDITION OF MERCHANTABILITY, FITNESS FOR A PARTICULAR PURPOSE (EVEN IF KNOWN TO TELTRONICS), NONINFRINGEMENT, SATISFACTORY QUALITY OR ARISING FROM A COURSE OF DEALING, LAW, USAGE, OR TRADE**

---

PRACTICE ARE HEREBY EXCLUDED TO THE GREATEST EXTENT ALLOWED BY APPLICABLE LAW. THIS DISCLAIMER AND EXCLUSION SHALL APPLY EVEN IF THE EXPRESS WARRANTY SET FORTH ABOVE FAILS OF ITS ESSENTIAL PURPOSE.

6. LIMITATION OF LIABILITY. IN NO EVENT WILL TELTRONICS BE LIABLE FOR INCIDENTAL, INDIRECT, SPECIAL, CONSEQUENTIAL, EXEMPLARY OR PUNITIVE DAMAGES OF ANY KIND EVEN IF THEY ARE FORESEEN OR FORESEEABLE. TELTRONICS' MAXIMUM CUMULATIVE LIABILITY RELATIVE TO ALL OTHER CLAIMS AND LIABILITIES, INCLUDING THAT WITH RESPECT TO DIRECT DAMAGES, WILL NOT EXCEED THE LICENSE FEE PAID FOR THE SOFTWARE GIVING RISE TO THE CLAIM OR LIABILITY. THESE DISCLAIMERS AND LIMITATIONS OF LIABILITY WILL APPLY REGARDLESS OF ANY OTHER CONTRARY PROVISION OF THIS AGREEMENT AND REGARDLESS OF THE FORM OF ACTION, WHETHER IN CONTRACT, TORT OR OTHERWISE, AND FURTHER WILL EXTEND TO THE BENEFIT OF TELTRONICS' SUPPLIERS, DISTRIBUTORS AND RESELLERS AS THIRD-PARTY BENEFICIARIES. EACH PROVISION IN THE AGREEMENT WHICH PROVIDES FOR A LIMITATION OF LIABILITY, DISCLAIMER OF WARRANTY OR CONDITION OR EXCLUSION OF DAMAGES IS SEVERABLE AND INDEPENDENT OF ANY OTHER PROVISION AND IS TO BE ENFORCED AS SUCH.

7. GOVERNING LAW, VENUE, AND JURISDICTION. This Agreement will be governed by and construed in accordance with the laws of the State of Florida but without regard to that state's conflict of laws principles. The parties agree that any action to enforce any provision of this Agreement or arising out of this Agreement or the business relationship between Teltronics and You will be brought in the state or Federal court of competent jurisdiction in the State of Florida. You and Teltronics agree that the United Nations Convention on Contracts for the International Sale of Goods (1980) shall not apply or govern this Agreement, the performance of, or any transaction between the parties under this Agreement. Reasonable attorney fees shall be reimbursed, with respect to the foregoing, to the party who prevails on the merits.

8. ENFORCEABILITY. If any provision of this Agreement shall be held to be invalid, illegal or unenforceable, the validity, legality or enforceability of the remaining provisions shall in no way be affected or impaired.

9. NO WAIVER. Any non-enforcement of any provision of this Agreement by Teltronics shall not constitute a waiver of such provision or prejudice Teltronics right to enforce such provision.

10. EXPORT COMPLIANCE. The Products including Software, product documentation and technology or direct products thereof ("Products and Technology") are subject to U.S. export control laws and regulations and the export of such Products and Technology is conditioned upon receipt of U.S. Government licenses and approvals. You shall ensure that no Products and Technology shall reach any country where U.S. law prohibits the possession or use of such Items. You shall comply with all export regulations of the U.S. Department of Commerce and shall not transfer any Products and Technology from the country of delivery, or to any facility engaged in the design, development, stockpiling, manufacturing or use of nuclear, missile, chemical or biological weapons, or to any military end-user or for a military end-use, without first obtaining Teltronics' written approval and all required approvals of the applicable U.S. agencies. Your obligations hereunder shall survive so long as You possess or control the Products and Technology.

11. THIRD PARTY LICENSE AGREEMENTS. A. You acknowledge and agree that installation and/or use of the Software may be subject to activation by license key.

B. Teltronics licenses or may license certain portions of its software from others, inclusive of certain components of the Software that consist of open source software ("GPL Software") subject to the GNU General Public License, Version 3, June 29, 2007 (the "GNU"), a copy of which will be provided to End User upon its written request to Teltronics, Inc. 2511 Corporate Way, Palmetto, FL 34221. GPL Software is not owned by Teltronics. Notwithstanding anything in this Agreement to the contrary, GPL Software is distributed by Teltronics to End User for End User's use solely under the terms of the GNU which govern the GPL Software and the copying, distribution, and modification of the GPL Software. Teltronics may also provide SMS (short message services) and

---

voice services for interoperating with the Software ("Third Party Software/Services"). Teltronics makes no representations or warranties as to such Third Party Software/Services or their operation, except to the extent such third party vendor provides such representation or warranty to Teltronics.

C. Vovida Software License (Version 1.0 Copyright (c) 2000 Vovida Networks, Inc. All rights reserved). Redistribution and use in source and binary forms, with or without modification, are permitted provided that the following conditions are met: (i) Redistributions of source code must retain the above copyright notice, this list of conditions and the following disclaimer; (ii) Redistributions in binary form must reproduce the above copyright notice, this list of conditions and the following disclaimer in the documentation and/or other materials provided with the distribution; (iii) The names "VOCAL", "Vovida Open Communication Application Library", and "Vovida Open Communication Application Library (VOCAL)" must not be used to endorse or promote products derived from this software without prior written permission. For written permission, please contact [vocal@vovida.org](mailto:vocal@vovida.org). (iv) Products derived from this software may not be called "VOCAL", nor may "VOCAL" appear in their name, without prior written permission of Vovida Networks, Inc. (v) THIS SOFTWARE IS PROVIDED "AS IS" AND ANY EXPRESSED OR IMPLIED WARRANTIES, INCLUDING, BUT NOT LIMITED TO, THE IMPLIED WARRANTIES OF MERCHANTABILITY, FITNESS FOR A PARTICULAR PURPOSE, TITLE AND NON-INFRINGEMENT ARE DISCLAIMED. IN NO EVENT SHALL VOVIDA NETWORKS, INC. OR ITS CONTRIBUTORS BE LIABLE FOR ANY DIRECT DAMAGES IN EXCESS OF \$1,000, NOR FOR ANY INDIRECT, INCIDENTAL, SPECIAL, EXEMPLARY, OR CONSEQUENTIAL DAMAGES (INCLUDING, BUT NOT LIMITED TO, PROCUREMENT OF SUBSTITUTE GOODS OR SERVICES; LOSS OF USE, DATA, OR PROFITS; OR BUSINESS INTERRUPTION) HOWEVER CAUSED AND ON ANY THEORY OF LIABILITY, WHETHER IN CONTRACT, STRICT LIABILITY, OR TORT (INCLUDING NEGLIGENCE OR OTHERWISE) ARISING IN ANY WAY OUT OF THE USE OF THIS SOFTWARE, EVEN IF ADVISED OF THE POSSIBILITY OF SUCH DAMAGE.

---

12. ENTIRE AGREEMENT. This Agreement and any written agreement executed by Teltronics and You for the supply of the Software and related Products represent the entire agreement between Teltronics and You and supersede all prior oral and written communications, agreements, promises, and understandings concerning the Software and related Products. In the event of any conflict between the terms of any written agreement executed by You and Teltronics and those of this Agreement, the terms of this Agreement shall prevail. Terms and conditions as set forth in any purchase order which differ from, conflict with, or are not included in this Agreement, shall not become part of this Agreement unless specifically accepted by Teltronics in writing.

---

## **TELTRONICS PRODUCTS FOR VOIP COMMUNICATIONS 911 EMERGENCY CALLING LIMITATIONS AND OBLIGATIONS**

(a) Customer, at Customer's cost, shall be responsible for procuring the supply, implementation, connection and support of any required telephone service including emergency 911 call service over the Internet and/or public switched telephone network ("PSTN") from one or more third party service providers as required for use of Products including without limitation, VOIP phone and Soft Phone software and hardware furnished by Teltronics or its distributors or resellers ("Products") for voice over internet protocol ("VOIP") communications.

(b) Customer are responsible for complying with all laws, rules and regulations applicable to the installation and use of Products (collectively, "Laws") including without limitation all Laws relating to 911 dialing for emergency service.

(c) 911 dialing to an appropriate public safety answering point ("PSAP") for emergency service is limited when using a VOIP phone and Soft Phone Product co-located with and connected to the switch Product at Customer's enterprise location because VOIP communication service may be interrupted, delayed, lost or terminated due to various causes including but not limited to power outage, excessive bandwidth consumption, termination of service with or by the network service provider and/ or other T1 provider, product, equipment, software, system and/or network failures or computer viruses. It is strongly recommended that Customer make alternative 911 dialing available to employees and other individuals at Customer's enterprise via traditional wire line service over the PSTN.

---

(d) Prior to initiating the use of Products in conjunction with any IP network including Internet telephone service for VOIP communications, Customer shall notify, in writing, each employee and any other person authorized to use the Products for such VOIP communications (individually and collectively “User(s)”) of the following limitations:

911 DIALING TO AN APPROPRIATE PUBLIC SAFETY ANSWERING POINT (“PSAP”) FOR EMERGENCY SERVICE IS NOT AVAILABLE WHEN USING ANY PORTABLE VOIP PHONE OR SOFTPHONE PRODUCT AT A STREET ADDRESS THAT IS DIFFERENT FROM THE STREET ADDRESS OF THE END USER’S ENTERPRISE WHERE ITS SWITCH IS LOCATED AND CONNECTED VIA AN IP NETWORK CONNECTION TO THAT REMOTE LOCATION. DO NOT USE SUCH PORTABLE VOIP PHONE OR SOFT PHONE PRODUCT AT THE REMOTE LOCATION TO PLACE 911 EMERGENCY CALLS BECAUSE SUCH PORTABLE VOIP PHONE OR SOFT PHONE IS NOT CAPABLE OF COMMUNICATING THE STREET ADDRESS OF THE REMOTE LOCATION.

EMERGENCY 911 CALLS SHOULD BE PLACED OVER A WIRE LINE PHONE AT THE REMOTE LOCATION WHICH IS CONNECTED TO TRADITIONAL PUBLIC SWITCHED TELEPHONE NETWORK (“PSTN”) FOR LOCAL SERVICE OR OTHER PHONE THAT IS CAPABLE OF COMMUNICATING THE STREET ADDRESS OF THE REMOTE LOCATION TO HELP INSURE THAT SUCH EMERGENCY 911 CALLS ARE ROUTED TO THE APPROPRIATE PSAP OPERATOR RESPONSIBLE FOR RESPONDING TO EMERGENCIES AT THE REMOTE LOCATION.

USERS MUST WARN ALL INDIVIDUALS AT THE REMOTE LOCATION THAT SUCH PORTABLE VOIP PHONE



---

OR SOFT PHONE PRODUCT CAN NOT BE USED TO PLACE ANY SUCH EMERGENCY 911 CALLS FROM THE REMOTE LOCATION BECAUSE OF THIS LIMITATION. USERS MUST INSTRUCT ALL INDIVIDUALS AT THE REMOTE LOCATION TO PLACE ANY 911 CALLS FOR EMERGENCY RESPONSE TO THE REMOTE LOCATION FROM A WIRE LINE PHONE AT THE REMOTE LOCATION WHICH IS CONNECTED TO THE TRADITIONAL PSTN FOR LOCAL SERVICE OR OTHER PHONE THAT IS CAPABLE OF COMMUNICATING THE STREET ADDRESS OF THE REMOTE LOCATION TO HELP INSURE THAT SUCH EMERGENCY 911 CALLS ARE ROUTED TO THE APPROPRIATE PSAP RESPONSIBLE FOR RESPONDING TO EMERGENCIES AT THE REMOTE LOCATION.

(e) If Customer permits any User to use the VOIP phone or Soft Phone Product at a remote location connected to the switch at Customer's enterprise location, it is strongly recommended that Customer affix a non removable label on the hand set of each VOIP phone or Soft Phone Product, prior to any such use that displays the following clear and conspicuous warning.

DO NOT USE THIS PHONE TO DIAL 911 EMERGENCY SERVICE CALLS UNLESS USER IS PHYSICALLY LOCATED AT THE FOLLOWING ADDRESS: (INSERT CUSTOMER'S ENTERPRISE ADDRESS WHERE THE PSAP WILL RESPOND TO 911 EMERGENCY CALLS DIALED THROUGH THE SWITCH).

---

(f) Customer agrees to defend, indemnify and hold harmless Teltronics, its subsidiaries, affiliates and their respective officers, directors, employees, distributor, agents and suppliers from any obligations, claims, suits, demands, causes of action, losses, liabilities, fines, penalties, damages, costs, or expenses, (including without limitation, attorneys fees), arising on account of any injury or death of persons, or damage to property asserted or incurred by or on behalf of any User, governmental entity or any other party arising out of or resulting from (i) any of Customer acts or omissions including without limitation, any failure of Customer to comply with any Laws; or (ii) any use, inability to use, removal, failure, delay, error, breakdown, absence, outage or interruption of any telephone service including emergency 911 call service over the Internet and/or PSTN or any software, hardware or Product including without limitation, any VOIP phone or Soft Phone Product.

# SUMMARY OF CHANGES

## Revision A, January 2010

- Initial Release

## Revision B, December 2010

- Added information for Arcata 2826 phone.
- Changed product name from Vision i-Phone to Arcata

---

This page intentionally blank

# SAFETY INSTRUCTIONS

## CAUTION

To reduce the risk of fire or injury to persons, read and follow these instructions before installing or operating the Arcata 28xx CIP-D:

- Follow all warnings and instructions marked on the unit and in the user and installation documentation.
- Read the installation instructions before you connect the system to its power source or to the LAN/IP connector.
- Do not place this unit on any unstable surface. It could fall causing serious damage or impeding operation.
- Do not use this unit in a location where it may come in contact with liquids. Be careful to not spill any liquids onto or near this unit.
- Never place this unit near or over a radiator or heat register.
- Unplug this unit from all connections before cleaning. Do not use liquid or aerosol cleaners. Use only a damp cloth for cleaning.
- Never push objects of any kind into this unit as they can touch dangerous voltage points or short-out parts that could result in a risk of fire or electrical shock.
- Do not use the unit to report a gas leak while in the vicinity of the leak.
- Do not disassemble the unit. Opening or removing covers can expose you to dangerous voltages or other risks. Incorrect re-assembly can cause electrical shock during subsequent use.
- Unplug this unit from all connections and refer servicing to qualified personnel when it requires repair work, service, or under the following conditions:

- 
- If the power supply cord or plug is damaged or frayed.
  - If liquid is spilled into the unit.
  - If the unit is exposed to water or rain.
  - If the unit does not operate normally by following the operating instructions.
  - If the unit is dropped or the casing is damaged.
  - If the unit exhibits a distinct change in performance.
- Ultimate disposal of this product should be handled according to all national laws and regulations.

**FAILURE TO FOLLOW THESE INSTRUCTIONS MAY VOID PRODUCT WARRANTY.**

**SAVE THESE INSTRUCTIONS!**

# INTRODUCTION

This guide details how to operate the Teltronics Arcata 2826 CIP-D and 2806 CIP-D phones (henceforth referred to as the 28xx CIP-D phone, unless specific differences are noted). See your system administrator for configuration issues or questions about installation and setup.

Be sure to read the *SAFETY INSTRUCTIONS* chapter before using your phone. FCC and Warranty information is detailed in the *FCC REQUIREMENTS* chapter.

## **Digital Support on the 2826 Phone**

The 2826 CIP-D is a business phone that transmits voice data over dedicated two-wire copper pair. The 2826 can connect to either an HDLU or an HDLU2 digital card on the Cerato switch and be configured as a digital endpoint.

See *Configuring the 2826 Phone* on page 24.

## **IP Support**

The 28xx CIP-D is a business phone that transmits voice data using the data network instead of traditional telephone lines, taking advantage of the economies of an existing network while retaining the capabilities and reliability of a standard telephone.

The 28xx CIP-D uses an IPEC to interface with the Teltronics Cerato switch, thereby retaining all the features of the Cerato and adding the advantages of IP telephony.

### Voice over the Company Network

The 28xx CIP-D combined with an IPEC can be used on the company data network, as shown in Figure 1.

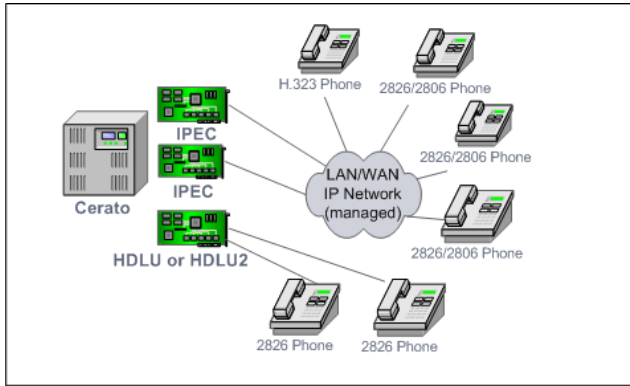

Figure 1. Voice over the company network

### Voice over Internet

The 28xx CIP-D can also be located at remote sites by using WAN services such as the Internet, as shown in Figure 2.

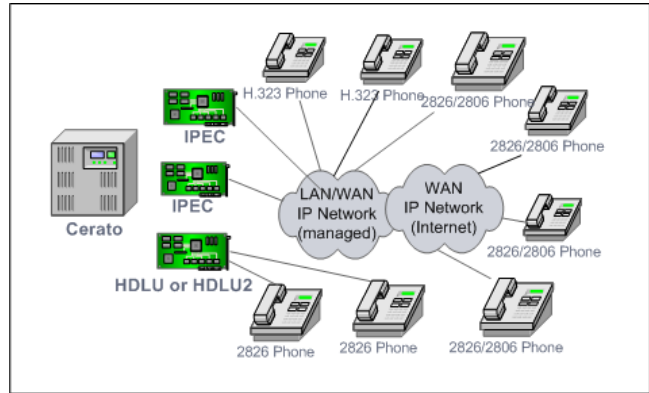

Figure 2. Voice over Internet



## 28xx CIP-D Features

The 28xx CIP-D has the following features:

\* Does not apply to a 2826 phone configured for a digital interface.

### Keys and Indicators

- 4 Soft keys
- 6 LED LINE keys (with LED line-in-use indicators)
- 10 Feature/Shared keys
- Optional BEM adds more keys depending on configuration
- Headset indicator
- Speaker indicator
- Mute indicator
- Hold indicator
- Voice mail message indicator
- Privacy indicator

- Forward indicator

### Display

- LCD – Text Display (9x22)

### Audio

- Adjustable Handset Volume Control
- Hearing-Aid Compatible
- Adjustable Headset Volume Control
- Automatic Headset Detection
- 10 Ring Tones to select from
- 4-position modular headset jack compatible with Plantronics and GN Netcom business headsets
- Adjustable Speakerphone Volume Control

**Phone Features**

- Date and Time
- 100 Entry Caller ID Log for Call History / Logging
- Last 100 number Redial List for Outbound Call Logging
- Message Waiting Indicator
- 100 Entry Directory
- 10 Entry Speed Dial List
- Advanced Call features (park, conference, transfer)

**Voice Mail Navigation**

One touch access to:

- Time and Date
- Reply to Sender
- Play
- Save

- Replay
- Skip
- Delete
- Forward

**Call Services**

Quick access to:

- Call pickup (this extension, group)
- Page (by zone)
- COM
- Privacy
- Forward (all, busy, no answer)
- View Extension

**Power options**

- Power over LAN (IEEE Standard)
- AC Line Input

**NOTE:** The power for a 2826 Digital phone is supplied from the tip and ring leads of the digital port of the 20-20 switch.

**Mechanical**

- Size: 10.75" x 7.75" x 2.25"
- Weight: 2.2 lbs.
- Color: Black

**Networking \***

- Dual 10/100 Switch full/half-duplex Ethernet ports
- 10/100 Base-T
- Auto Negotiation & Parallel Detection
- RJ-45, Category 5 per IEEE 802.3

**Audio Codec Supported \***

- G.711, G. 729AB
- Automatic Codec Negotiation
- Voice Activity Detection (VAD)
- Silence Suppression

**Voice Transport \***

- G.711, G.729AB
- Receive Jitter Buffer Provisioning
- Packetization Rate Provisioning

**Quality of Service (QoS) \***

- 802.1q
- 802.1p
- VLAN

### **Certifications \***

- TIA 810
- USA FCC Part 15, Class A
- USA ULC
- IEEE Standard 802.3af option B

### **Protocols \***

- TCP/IP (Transmission Control Protocol / Internet Protocol)
- UDP (User Datagram Protocol)
- RTP (Real Time Transport)

### **DTMF Support \***

- In-band DTMF Signaling
- Out-of-band DTMF signaling

### **IP Address Configuration \***

- DHCP
- Static Address

- DNS Support

### **Configuration**

- Password Protection
- Remote software upgrade
- Mass update of software upgrades
- Menu based configuration of system settings
- Directory, speed dial, redial, call record migration

Components

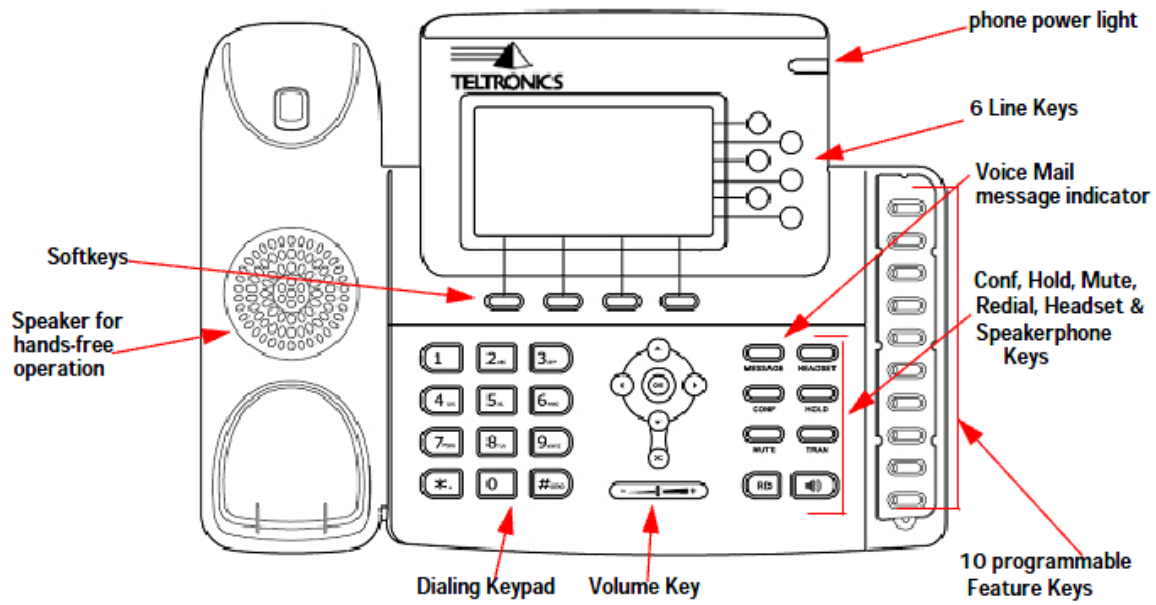

Figure 3. Arcata 28xx CIP-D Components

**Navigation Keys**

Cancel	Up	Down	Left	Right	Confirm

Use the navigation keys to move within the display menus and to confirm or cancel actions.

**Audio Device Control Keys**

Use the audio device control keys to perform the following actions depending on your phone type:

Adjust the volume of the handset, headset, speaker, and ring tone.

**Speakerphone:** allows for hands-free communication during calls.

**HEADSET** Place and receive calls through an optionally connected headset. The LED is on when the phone is in Headset mode.

**MUTE** Mute audio transmission locally during

**Hard Feature Keys**

**MESSAGE** Allow users to access voice mail directly.

**CONF** Enable setup of a local multiple line conference.











**HOLD** Place a call on hold or resume it.





**TRAN** Transfer current call to third party.

**RD** Dials most recently dialed number.

**Icon Instruction**

The phone displays different kinds of icons on its LCD. Refer to the following table for their meanings:

Icons	Description
	Missed calls
	Call in
	Call out
	Input Method: all letters and numbers
	Input Method: numbers
	Input Method: letters in lower case
	Input Method: letters in upper case
	Call mute
	Call hold
	Voice mail

	Call forward
	DND (Do not Disturb)
	In Handset mode
	In Headset mode
	In Speakerphone mode

## Quick Tour of the 28xx CIP-D

The 28xx CIP-D was designed to be easy to operate. The functionality of the phone is detailed in alphabetical, step-by-step instructions in the *Using the Arcata 28xx CIP-D* chapter.

This section gives extra tips on using the LCD menus so you can quickly start using the phone. Refer to *Figure 1, Arcata 28xx CIP-D Components*, when reading this section.

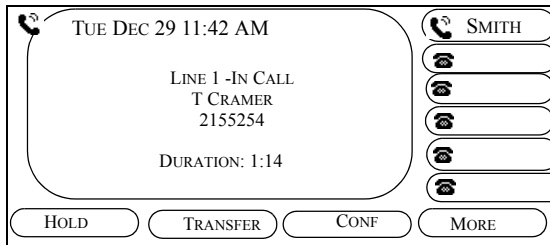

**Call Answered LCD Screen**

## LCD Operation

The 28xx CIP-D has Feature/Share keys that the System Administrator can configure for various features, such as: Intercom (COM), Park, Redial, Account Code Calling, Appointment Reminder, and Callback.

Note that you can create soft labels the first six features via the Line Key Labels menu accessed via the **Menu** soft key.

In addition to the feature/share keys and the traditional physical keys on the 28xx CIP-D has four soft keys located below the LCD that are used with menus that display on the LCD.



Soft keys change functionality depending on what screen is displayed on the LCD.

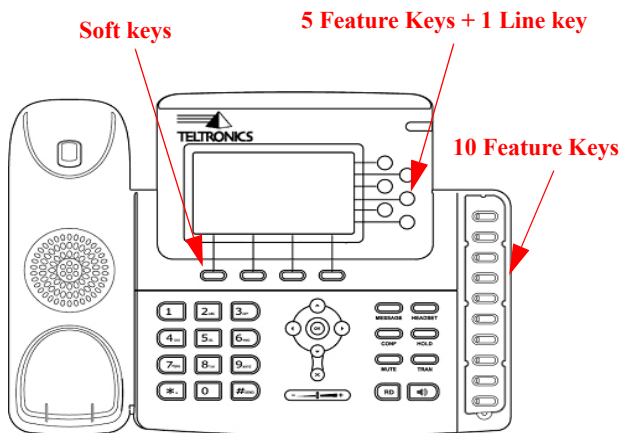

### Purpose of LCD

The LCD is used for viewing system information and to set up and use the phone's features. In addition, the system administrator uses the screens on the LCD to install and configure your 28xx CIP-D.

### Accessing LCD menus

You can access the LCD by pressing the following keys:

- Soft keys located directly below the LCD (i.e. **HISTORY, DIRECTORY, FEATURES, MENU**)
- **VOLUME** key
- **NAVIGATE** keys - changes LCD pages
- and the Feature/Shared keys

To view system information about your phone, see *VIEWING PHONE SETTINGS on page 81*. Note that only the System Administrator can change system settings.

### Navigating the LCD menus

The following list describes how to navigate menus displayed on the LCD:

- Selecting an option on LCD menu - press the LCD key below the option.
- **BACK** - returns to the last LCD menu page.
- **SAVE** - saves the changes and returns to the last LCD menu page.
- **CANCEL** - deletes the changes on the selected LCD page and returns to the previous LCD menu page
- Dialing Keypad - Press keys on the Dialing Keypad to enter letters and numbers on the LCD. Press the key more than once to select subsequent letters (for example, press the '2' key 3 times to get a 'C').
- Period Delimiter - To get the period delimiter (e.g. 172.168.40.2) to display, use the Asterisk (\*) key on the Dialing Keypad.
- **NAVIGATE** keys - Press the Up and Down and Left and Right Arrows on the NAVIGATE group of keys to access subsequent pages on multiple page menus on the LCD (for example, PG 1 of 2). LCD Menu pages display corresponding arrows.
- **RIGHT** - used to add a space, such as between a first and last name.
- **BACK** - used to replace a wrong character.
- **CLEAR** - used to quickly remove the entire character string.
- **DIAL** - dials the entry
- **ADD TO SPEED DIAL** - copies the current entry to the Speed Dial List

- **ADD TO CONTACTS** - copies the current entry to the Contact List

This page intentionally blank.

# PHONE SETUP

## Getting Started

### Packing List

The following components are included in your package. Check this list before installation to ensure that you have received each item. If you are missing any items, contact your IP phone reseller.

- Arcata 28xx CIP-D

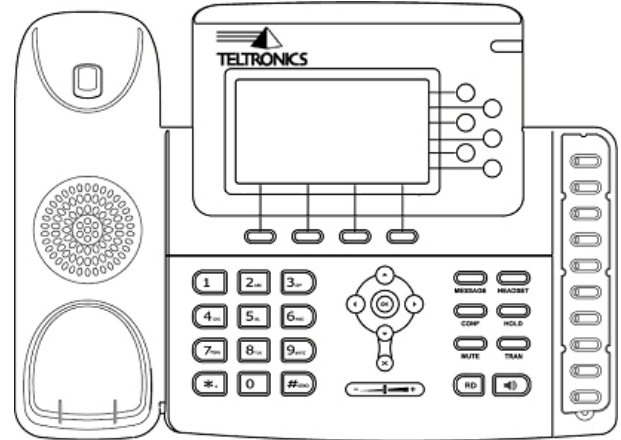

## PHONE SETUP

---

- Phone Stand

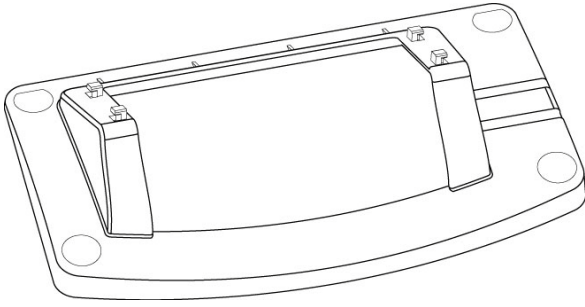

- Ethernet Cable

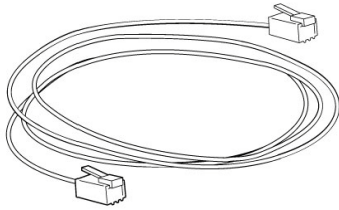

- Power Adapter

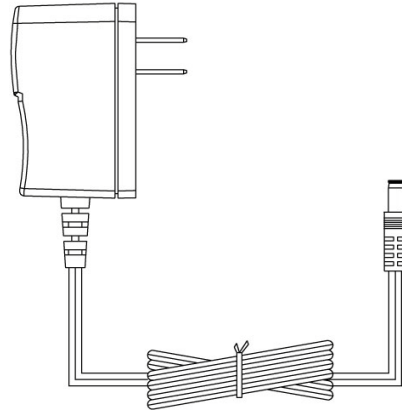

**Note** The AC Power Adaptor is not provided in the packing list. Please contact your distributor for more information

- Handset & Handset Core

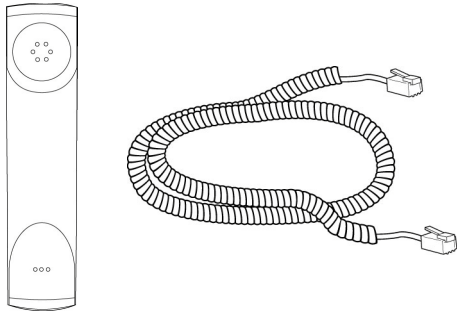
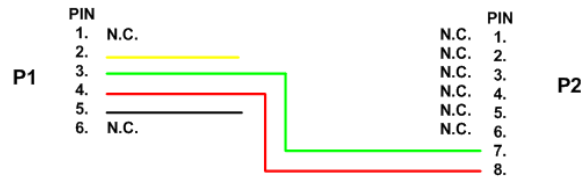

**Figure 4. RJ11-to-RJ45 Cable**

- RJ11-to-RJ45 cable

This cable is provided for 2826 phones configured as a digital endpoint. Use the cable to connect the PC port on the back of the 2826 phone to the RJ11 connection on an HDLU or HDLU2 card in the 20-20.

A 10' cable (p/n: 551-2000-0182) is supplied with the phone. A 20' cable (p/n: 551-2000-0183) can be ordered separately.



\*Wire colors are shown for reference only and depict the color scheme for standard, 4-wire, silver-satin type phone cord.

**Figure 5. RJ11-to-RJ45 Cable Pinout**

**Assembling the Phone**

This section shows how to assemble the phone with the components in the packing list.

1. Attach the stand.

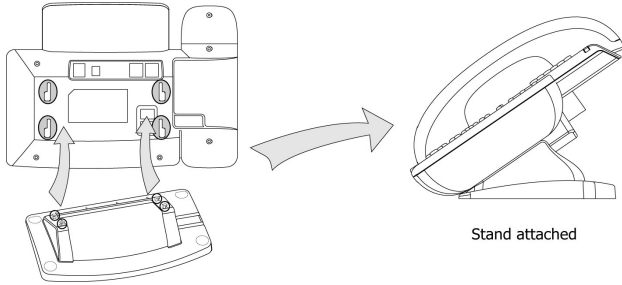

2. Connect the handset and headset.



**Note** Headset is not provided in the packing list. Please contact your distributor for more information

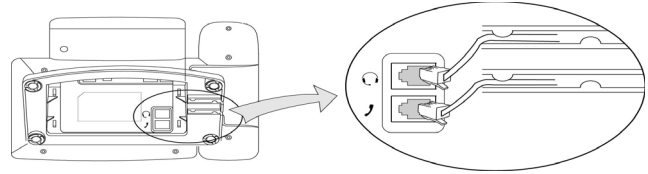
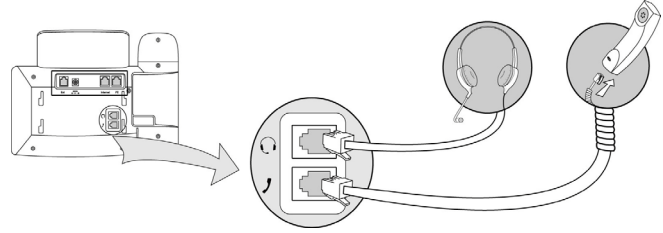



## 3. Connect to the network and power.

**NOTE:** If you are using a 2826 phone as a digital endpoint, see *Configuring the 2826 Phone* on page 24.

You can connect the network and power source in either of two ways. (Your system administrator will advise you on which one to use):

- Use a PoE-compliant switch or hub.

**IMPORTANT:** Do not connect a 2826 phone configured as a digital endpoint to a PoE-compliant switch or hub.

- Connect the phone to the AC power directly using the power adapter.



**Note** If inline power is provided, do not install the AC adapter. Make sure the Ethernet cable and switch/hub is PoE compliant (except for a 2826 configured as a digital endpoint).

The Internet Port can also be connected to a Hub/Switch/IP PBX or other internet devices.

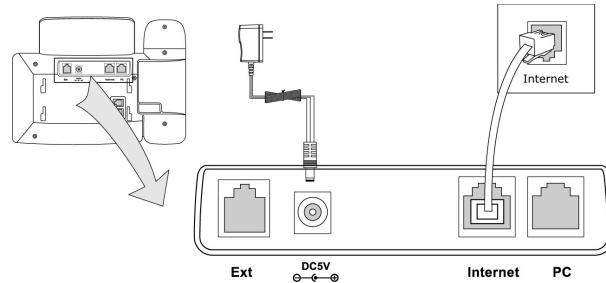

## PHONE SETUP

---

- The 28xx phone can also share the network connection with other network devices, such as a PC. Connect the phone's PC port and the computer's network port using an Ethernet cable, as shown below.

**NOTE:** If you have a 2826 phone configured as a digital endpoint, you connect the PC port to the Cerato 20-20 using the special cable provided. See RJ11-to-RJ45 cable on page 17.

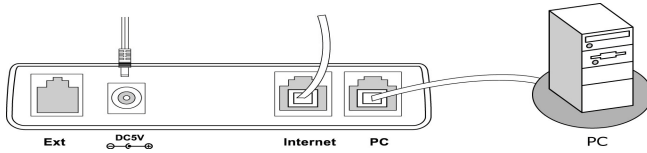

- Press the **OK** button on the Navigation Keys.

The phone will reboot, and on your PC you should see the phone connecting and downloading the rom file.

When the phone comes back up, verify that the correct firmware version has been loaded by pressing the **Menu** soft key and then the DTMF digit **2**.

- Disconnect the Ethernet Cable from the phone.

### Installing an Expansion Module (Optional)

The Teltronics EXP38 Expansion Module is designed for improving the power and flexibility of Teltroncis phones. It features 38 fully programmable DSS keys each with a dual-color LED, connected to and controlled by the phone with an RJ-12 cable line.

**NOTE:** The Cerato System supports a total of 48 buttons. In addition to the 19 buttons on the 28xx phone, you can configure up to 29 buttons on the Expansion Module.

Teltroncis phones support the functions such as speed dialing, BLF, Shared, and Park on each of the programmable buttons on the EXP38.

The Teltroncis EXP38 is ideal for receptionists, administrative assistants, power users, and executives who need to monitor and manage a large volume of calls on a regular basis.

### Packing List

The Expansion Module includes the following parts:

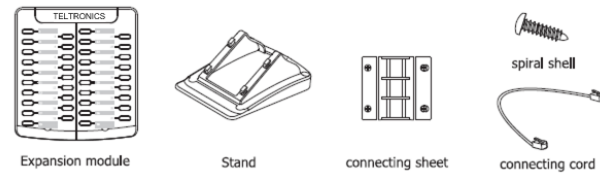

### Specifications

- 2xRJ-12(6P6C) ports for data in and out
- Weight: 255g
- Dimensions: 132x143x42mm
- Operating humidity: 10~95%
- Storage temperature: max 140 F (60 C)

**Steps**

1. Use the connecting sheet and screw to connect the EXP38 to the phone.

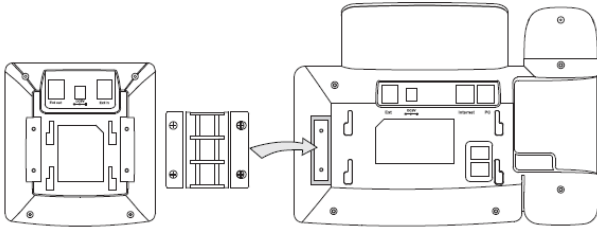

The EXP38 and the phone should be connected as shown below:

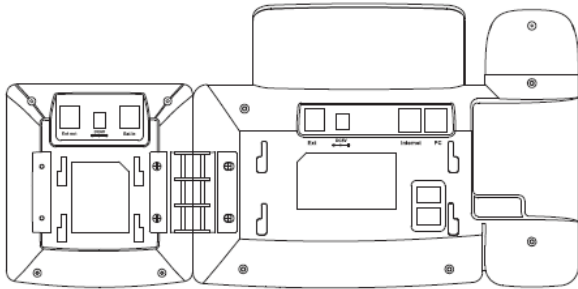

2. Plug the connecting cord into the **Ext** jack of the phone and then to the **Ext** jack on the Expansion Module.

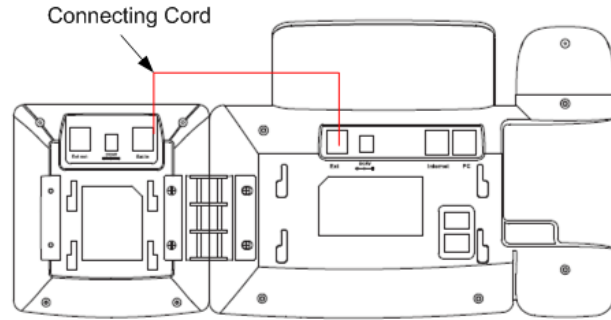

3. Connect the stands and the user-supplied power adapter.

## Expansion Module Numbering

When configuring the Expansion Module buttons in the Cerato System, the buttons are numbered as shown below:

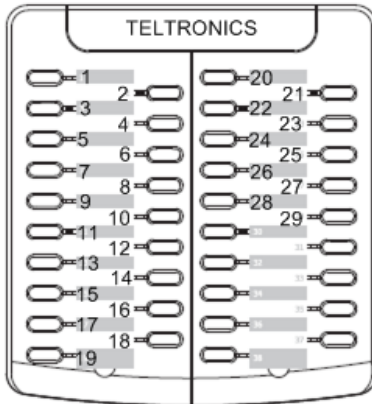

## Downloading Firmware from the Cerato 20-20

This section is intended for System Administrators. Do not make any changes to your phone without consulting System Administrator.

**NOTE:** Requires Cerato 20-20 switch software release 4.3 or above.

If you have no other way to download firmware to the phone, you can enable the Switch Download feature to have the phone download new firmware from the Cerato 20-20.

Note that this method takes considerably longer than TFTP. You should disable the feature after downloading firmware.

1. Press the **Menu** button.
2. Press DTMF digit **3** (Modify Settings).
3. Press DTMF digit **3** (Phone Settings).
4. Press DTMF digit **4** (Switch DwlD).
5. Use the right Navigation Key to select *Enable*.

## Configuring the 2826 Phone

**NOTE:** This section is intended for System Administrators. Do not make any changes to your phone without consulting System Administrator.

### Digital Interface Loop Limits

- Digital Interface Loop Limits  
26 AWG - 500 m for Tip and Ring
- Digital Interface Power Requirements  
2.5 W supplied by the switch

## Line Type

The 2826 can connect to either an HDLU or an HDLU2 digital card on the Cerato switch. Configure the Line Type according to the card to which the phone is connected.

To configure the Line Type:

1. Press the **Menu** button.
2. Press DTMF digit **3** (Modify Settings).
3. Press DTMF digit **3** (Phone Settings).
4. Press DTMF digit **3** (Line Type).
5. Use the right Navigation Key to select the desired Line Type.

## Converting the 2826 to CIP-D or SIP

The 2823 phone is configured as a digital endpoint. To change the phone to a CIP-D or SIP endpoint, perform the following:

1. Setup a TFTP Server and load the appropriate firmware files provided by Teltronics:  
T28.rom (SIP)  
ccip.rom (CIP-D)
2. Connect an Ethernet Cable to the Ethernet port on the back of the phone.

The phone will come up using DHCP.

3. On the phone, press the **Menu** soft key followed by the DTMF digit **2**.
4. Write down the IP configuration that the phone received from DHCP: IP Address, IP Netmask, and IP Gateway.
5. Power down the phone by disconnecting the Ethernet cable.

6. Press and hold the **Speaker** button while you plug the Ethernet cable back into the Internet port and continue pressing while the phone boots up.

The phone will boot up in "Safe Mode", allowing you to upgrade the phone.

7. Enter the IP address from step 4.
8. Enter the IP address of the TFTP Server where the rom files are located.
9. In the **Protocol** field select the desired application (SIP or CIP-D).

**NOTE:** Use the down Navigation Keys to move through fields. Use the right Navigation Key to select the Protocol.

10. Press the **OK** button on the Navigation Keys.

The phone will reboot, and on your PC you should see the phone connecting and downloading the rom file.

11. When the phone comes back up, verify that the correct firmware version has been loaded by pressing the **Menu** soft key and then the DTMF digit **2**.
12. Disconnect the Ethernet Cable from the phone.



## USING THE ARCATA PHONE

This chapter details step-by-step instructions (in alphabetical order) on how to use the Arcata 28xx CIP-D. Click on a procedure to go to that page.

*ACCOUNT CODE CALLING*  
*ANSWERING CALLS*  
*APPOINTMENT REMINDER*  
*CALLBACK*  
*CANCEL/HANG UP*  
*CONFERENCE*  
*CONTACT LIST*  
*DIAL*  
*DIRECTORY*  
*FEATURES*  
*FORWARD*  
*HEADSET*  
*HOLD*  
*INTERCOM (COM) CALLING*  
*LINE KEY LABELS*  
*MENU*

*MUTE*  
*PAGE*  
*PARK*  
*PARK PICKUP*  
*PICKUP (Group and Directed)*  
*PRIVACY*  
*REDIAL*  
*RING TONES*  
*SPEAKERPHONE*  
*SPEED DIAL*  
*TIME AND DATE*  
*TRANSFER*  
*VIEW EXTENSION*  
*VOICE MAIL*  
*VOLUME*  
*WEB CONFIGURATION*

## ACCOUNT CODE CALLING

The Account Code Calling feature is used to bill a call to an specific account or project.

Check with your system administrator about the exact method of entering an account or project identification number.

**Note** See the *ACCESS CODES AND AUDIBLE TONES* chapter for a table of access codes for your phone.

### To set up Account Code Calling:

1. Lift the handset and dial the Account Code Calling access code \_\_\_\_\_.
2. Dial the specific account or project identification number.
3. Dial \* to indicate the end of the specific account or project identification number. Hear a dial tone.
4. Dial the desired external telephone number, using the access code for an outside line (e.g., '9') and area code.

**ANSWERING CALLS**

When an incoming call comes into the Arcata 28xx CIP-D, the following screen appears on the LCD:

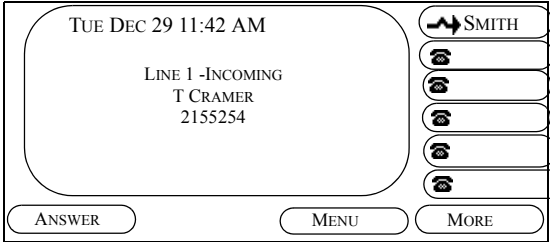

**Incoming Call LCD Screen**

**To answer a call:**

1. Do one of the following:
    - Lift the handset. or press the **ANSWER** soft key
- or

- Press the **SPEAKER** or **LINE** key to turn on the Speakerphone.
- Press the **HEADSET** key. The headset is automatically detected if connected to the Headset port on the back of the phone.

*Note* The Line Key LED turns green.

2. Start speaking to the caller.

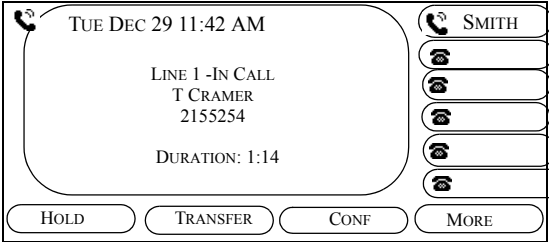

**Call Answered LCD Screen**

### **Automatic Ringing Line Selection:**

If multiple calls come in simultaneously, when you lift the handset, press **SPEAKER**, **LINE X**, or **HEADSET**, the lowest numbered line is answered.

### **Automatic Idle Line Selection:**

If you have a call on hold (or accessed from a Shared appearance on another phone) when you lift the handset, press **SPEAKER**, **LINE X**, or **HEADSET**, the next available Line is selected.

### **To hang up:**

Do one of the following:

- Replace the handset or press the **LINE** key.
- Press the **SPEAKER** key.
- Press the **HEADSET** key.

**Related topics:** Park, Conference, Hold, Transfer, Hangup, Speakerphone, Headset

## APPOINTMENT REMINDER

The Appointment Reminder feature lets you set up a reminder call that will ring at a specified time. You can set up a maximum of three reminder calls within 24 hours.

**Note** See the *ACCESS CODES AND AUDIBLE TONES* chapter for a table of access codes for your phone.

**Note** See the System Administrator to see if the Timed Reminder or Remote Timed Reminder features have been enabled for your phone.

### To set up a reminder call:

1. Dial the Set Up Access Code:\_\_\_\_\_
2. Hear the confirmation tone,
3. Enter the time of the reminder in a 24-hour format (i.e., 0600 = 6:00 am).
4. Hear the confirmation tone.
5. Replace handset.

### To cancel a reminder:

1. Dial the Cancel Access Code:\_\_\_\_\_
2. Hear the confirmation tone. The reminder is cancelled.

### Remote Appointment Reminder:

The Remote Appointment Reminder lets you set up or cancel a reminder call for another extension.

### To set up a remote reminder call:

1. Dial the Remote Set Up Access Code:\_\_\_\_\_
2. Hear the confirmation tone.
3. Dial extension number.
4. Hear the confirmation tone.
5. Enter the time of the reminder in a 24-hour format (i.e., 0600 = 6:00 am).

6. Hear the confirmation tone.
7. Replace handset.

**To cancel a remote reminder:**

1. Repeat Steps 1 - 4 using the Remote Cancel Access Code: \_\_\_\_\_

## CALLBACK

There are several types of Callback described here:

- station
- trunk

**Note** See the *ACCESS CODES AND AUDIBLE TONES* chapter for a table of access codes for your phone.

### Station Callback

The Callback feature places an automatic callback on an extension that is busy or does not answer. When the party you called hangs up or returns and uses his or her phone once, your extension will ring. If you answer the callback, the system dials the extension.

### To set up a Station Callback:

1. When making a call, you hear the busy signal or the call rings without being answered.
2. Dial the Callback Access Code (2) or press the Callback feature button if configured by the System Administrator. Hear the confirmation tone.
3. Replace the handset.
4. Hear ringing.
5. Lift the handset and wait for answer.

### To cancel a Station Callback:

1. Dial the extension with Callback set up and then replace the handset.

**To set up On-Hook Queueing (Trunk Callback):**

1. After you dial for an outside line, hear the Off-hook Queue tone (three beeps followed by a hold tone), or the On-Hook Queue tone (a repeated sequence of three tones in a rising scale).
2. Dial the Callback Access Code (2) or press the Callback feature button if configured by the System Administrator. Hear the confirmation tone.
3. Hang up.
4. When you hear the triple ring callback, lift the handset and wait for the called party to answer.

**Note** When there are no available outside lines to place your call, “On-Hook Queueing” lets you hang up and remain in queue for one. Once an outside line is available, “Off-Hook Queueing” automatically calls you back with a triple-ring. After you answer the callback, “On-Hook Queueing” redials the party's number for you.



---

## CANCEL/HANG UP

Depending on the current procedure in progress, there are several ways to hang up or cancel a call or operation.

### To cancel or hang up a call:

Do one of the following:

- Replace the handset or press the **LINE** key.
- Press the **SPEAKER** key.
- Press the **HEADSET** key.

### To cancel an LCD operation:

Press the **CANCEL** or **BACK** soft key.

**Related topics:** Answering calls, Speakerphone, Headset

**CONFERENCE**

The Conference feature allows you to talk with two or more parties simultaneously.

**To use the Conference feature:**

1. While in conversation with the first party:
2. Press the **CONF** key or soft key. The first party is put on hold as you hear dial tone.

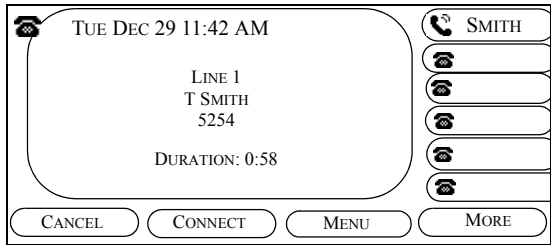

**Call in Progress LCD Screen**

3. Dial the extension or phone number of the second party.
4. When the second party answers, you may

5. speak with him or her while the first party is still on hold.

5. Press the **Conf** key or the **Connect** soft key to connect all three parties in conference..

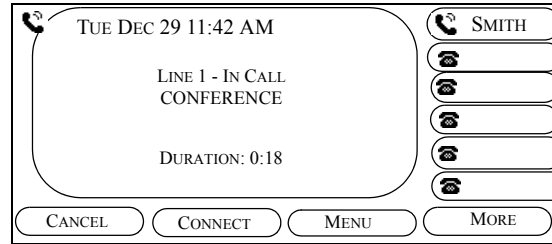

**In Conference Screen**

6. Repeat steps 3 through 5 to add more parties to the conference call.

*Note* Press the **More** soft key, then the **End Call** soft key to cancel the conference.

**Related topics:** Answering calls, Speakerphone, Headset, Cancel/Hangup, Transfer

**CONTACT LIST**

The Contact list enables you to build your own list of contacts to quickly dial, get detail about the call, or add to the Speed Dial list.

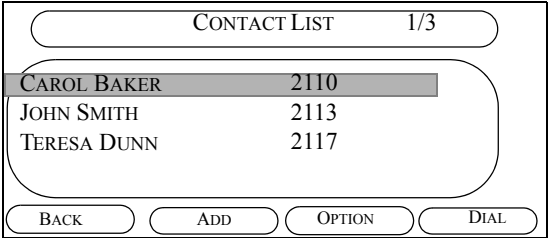

**Contact List screen**

**To open the Contact List:**

1. Press the **Directory** soft key.
2. Scroll to the Contact List option and press OK. The Contact List page appears.

**To Dial a contact:**

Scroll to the entry of the caller you wish to dial and press the Dial soft key. The extension rings.

**To Copy a contact to Speed Dial:**

1. From the main Contact List screen, scroll to the desired caller, then press the **Option** soft key. A submenu opens.
2. Scroll to the **Add to Speed Dial** option and press OK. The Select Position screen appears.

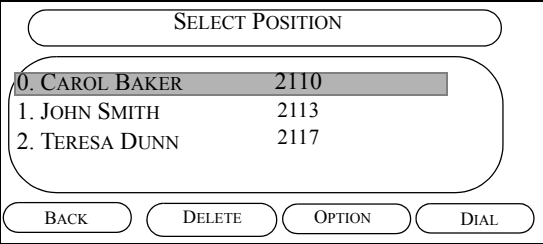

**Select Position screen**

3. Scroll to the position in the list you wish to add the contact to and press the **Select** soft key. The Detail screen for that contact appears.
4. Press the **Save** soft key.

The call record is added to the Speed Dial list.

**To add a new listing to the Contact List:**

1. Press the **Add** soft key. The Add Contact screen displays.

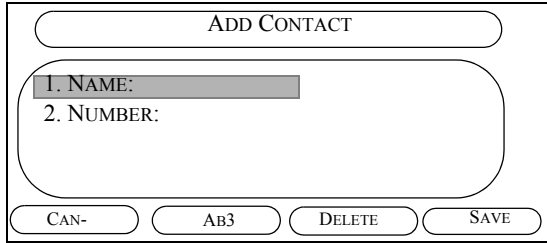

**Add Contact Screen**

2. Press the **Ab3** soft key to toggle to the ABC soft key, then enter the name of the new contact
3. Scroll down to the Number: field.

4. Press the **ABC** soft key to toggle to the 123 soft key, then enter the extension of the new contact.
5. Press the **Save** soft key. The new contact appears in the Contact List.

**To edit an existing contact:**

1. Press the **Option** soft key. A submenu opens.

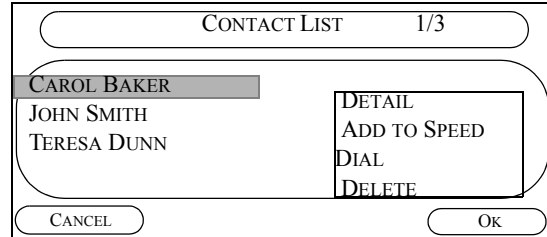

**Contact Screen**

2. Scroll to the **Detail** option on the submenu and press the OK soft key. The edit screen for the selected contact opens.

**Related topics:** Answering calls, Speakerphone, Headset, Directory, Speed Dial

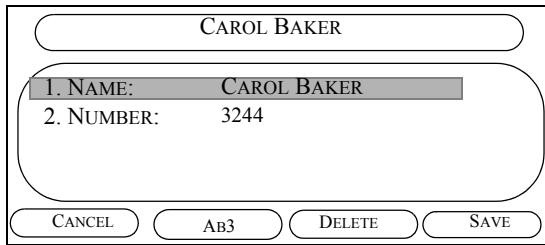

The screenshot shows a contact edit screen for 'CAROL BAKER'. At the top, the name 'CAROL BAKER' is displayed in a rounded rectangular field. Below this, there are two fields: '1. NAME: CAROL BAKER' and '2. NUMBER: 3244'. The '1. NAME' field is highlighted with a grey background. At the bottom of the screen, there are four soft keys: 'CANCEL', 'AB3', 'DELETE', and 'SAVE'.

3. Use the **Delete** soft key and the **Ab3/ABC/123/abc** toggle soft keys to change the name and/or number of the contact.

#### To delete a Contact:

1. Scroll to the desired contact.
2. Press the **Option** soft key.
3. Scroll to the **Delete** option and press OK. The contact is removed from the Contact List.

**DIAL**

**To Dial a call:**

**Note** The Arcata 28xx CIP-D has six LINE keys for incoming and outgoing calls.

1. Do one of the following to get dial tone:
  - Lift the handset or press a **LINE** key
  -  Press the **SPEAKER** key to turn on the Speakerphone, or start dialing digits to automatically select the Speakerphone
  - Press the **HEADSET** key. The headset is automatically detected if connected to the phone.

2. Press the keys on the Dialing Keypad of the number you wish to dial, using the outside line access code, if necessary. The number is dialed.

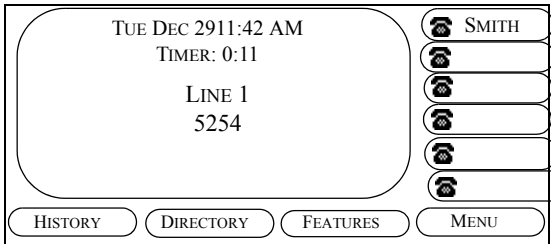

**On Hook Screen**

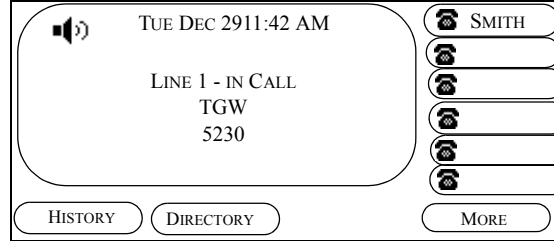

**Dialing Ext 5230 screen**

**Note** See the *ACCESS CODES AND AUDIBLE TONES* chapter for the outside line access code for your phone.

3. When the other party answers, the LCD screen below appears:

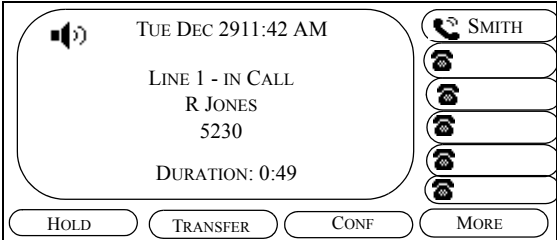

**Connected to Ext 5230 Screen**

## DIRECTORY

The Directory soft key provides access to the Contact and Speed Dial lists.

1. Press the Directory soft key. The Directory Menu page appears:

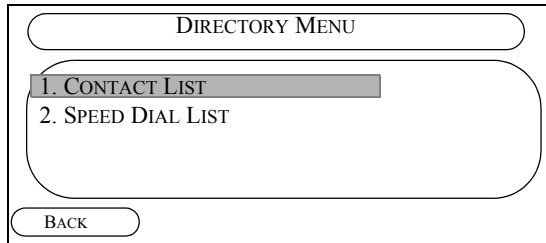

**Directory Screen**

### To access the Contact List:

1. Scroll to the Contact List option and press OK.
2. See the instructions on using the Contact List in this chapter.

### To access the Speed Dial List:

1. Scroll to the Speed Dial List option and press OK.
2. See the instructions on using the Speed Dial List in this chapter.

**Related topics:** Contact List, Speed Dial



## FEATURES

The Features soft key allows you to access several miscellaneous features as shown on the Features LCD screen:

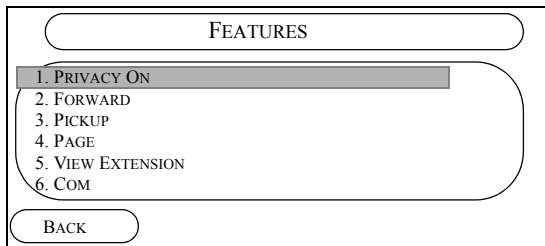

**Features LCD Screen**

- PRIVACY
- FORWARD
- *PARK PICKUP*
- PAGE
- VIEW EXTENSION
- INTERCOM (COM) CALLING

3. Click on a feature in Step 2 to see details about it.

**Related topics:** Privacy, Forward, Park, Pickup, Page, View Extension, Intercom (COM) Calling

### To access Features:

1. From the mainscreen, press the **Features** soft key. The Features menu appears.
2. Scroll down to a desired feature and press OK. The Features page accesses the following features:

**FORWARD**

The Forward feature allows you to specify what type of calls to forward to another extension when the Forward feature is turned on:

- all calls
- busy
- no answer
- busy or no answer

**To Forward a call:**

1. Press the **Features** soft key to display the Features menu:

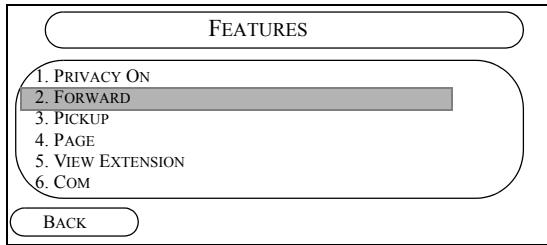

**Features Screen**

2. Scroll to the **Forward** option and press OK.

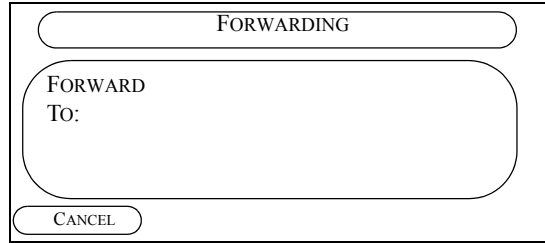

**Forwarding Screen**

3. Enter an extension to forward calls to on the Dialing Keypad.

The Forwarding Mode menu displays.

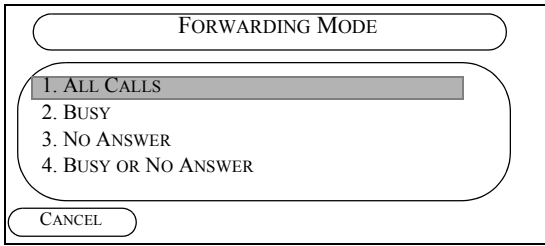

**Forwarding Mode Screen**

4.  Select a Forwarding option. The Forward feature is activated and a blinking **Forward** icon appears on the main screen to indicate the feature is on, until you cancel it as described in the next section.

**To Cancel Forwarding:**

1. Press the **Features** soft key to display the Features menu.

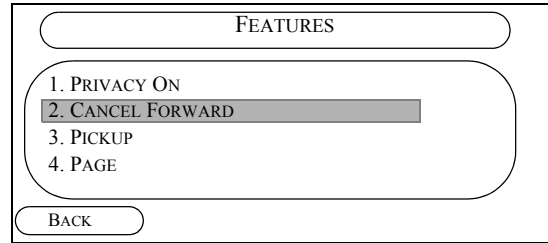

**Features Screen to toggle off Forward**

2. Toggle to the **Cancel Forward** option. The Forward icon is removed from the main screen and the feature toggled off.

**Related topics:** Answering calls, Speakerphone, Headset.

## HEADSET

The Arcata 28xx CIP-D automatically detects a headset when a headset is connected to the phone as described here.

### To connect a headset to the Arcata 28xx CIP-D:

1. Plug the headset into the **HEADSET** port on the bottom of the phone.
2. ? Unplug the handset from the **HANDSET** port on the left side of the Arcata 28xx CIP-D and plug it into the Headset.

### To toggle from headset/handset:

1. Press the **HEADSET** key. The phone will toggle between the headset and the Phone port on the handset.

**Note** To change the volume on the headset, see *VOLUME section* on page 75.

### To hang up a call:

1. Press the **HEADSET** or **LINE** key.

**Related topics:** Answering calls, Speakerphone, Headset

**HISTORY**

The History list provides several different ways of viewing the last up to 100 previous calls:

- All Calls
- Dialed Calls
- Received Calls
- Missed Calls

To scroll from list to list, press the left or right Navigate keys.



The lists are menus of the last 100 callers in the order they were received. When a call is received, the caller's information (a call record) is stored in the History list. If the maximum number of calls is reached for the History list, when the newest (101st) call record comes in, the oldest (1st) is overwritten.

You can review details, dial, delete and copy the call record to the Speed Dial or Contact lists with the History feature.

The History lists use icons to the left of the caller's name to describe the type of call.

See the following table for a description of the icons:

Icon	Description
	dialed calls
	missed calls
	received calls

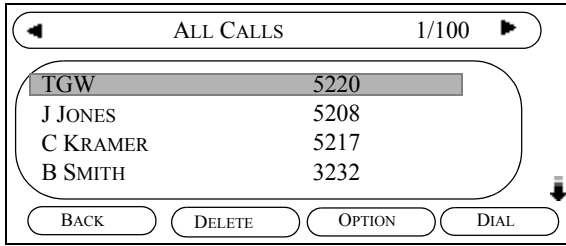

**History screen**

**To open the History list:**

Press the **History** soft key.

**To scroll through the History lists:**

From the **History** list main page, use the left and right Navigation keys to scroll through the four types of organized History lists: All Calls, Dialed Calls, Received Calls, Missed Calls.

**To Dial a caller:**

Scroll to the entry of the caller you wish to dial and press the Dial soft key. The extension rings.

**To get details about a caller:**

When calls come in that you miss, a text message '1 missed call' appears on the phone main

screen. Details about these calls can be viewed on the History screen, as follows.

1. From the main History screen, scroll to the caller you wish to get details for, then do one of the following:
  - press the **Option** soft key, then select **Detail**
  - press OK

The call record for that person displays.

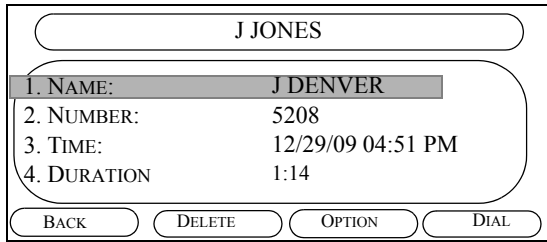

**Call Detail Screen**

**To Copy a call record to Speed Dial:**

1. From the main History screen, scroll to the desired caller, then press the **Option** soft key.
2. Scroll to the Add to Contacts option and press **OK**.

The call record is added to the Speed Dial list.

**To Copy a call record to the Contacts list:**

1. From the main History screen, scroll to the desired caller, then press the **Option** soft key.

2. Scroll to the Add to Contacts option and press **OK**.

The call record is added to the Contacts list.

**To delete a record from the History list:**

1. From the main History screen, scroll to the desired caller, then press the **Option** soft key.
2. Scroll to the Delete All option and press **OK**.

The call record is deleted from the History list.

**To delete all records from the History list:**

1. From the main History screen, press the **Option** soft key.
2. Scroll to the Delete All option and press **OK**. The Warning screen appears.
3. Press the **Yes** soft key to answer the question 'Delete all records?'

**Related topics:** Park, Conference, Transfer, Hangup, Speakerphone, Headset

**HOLD**

**To place a caller on hold:**

1. While in conversation:

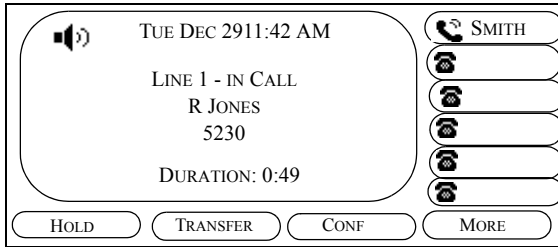

**Call Answered LCD Screen**

2. Press the **HOLD** key or soft key. The LINE key LED blinks green while the caller is placed on hold.

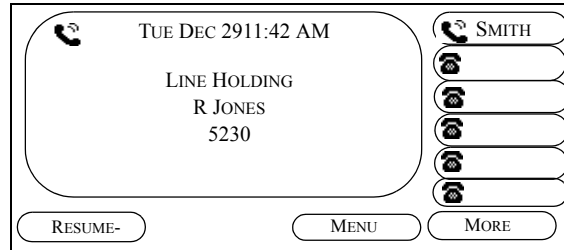

**To remove a caller from hold:**

3. Press the blinking **LINE** key or the Resume soft key. The caller is removed from hold and you can begin talking.

**Related topics:** Answering calls, Speakerphone, Headset



## INTERCOM (COM) CALLING

COM calls (internal only) override “Call Forward” and ring the called extension with a distinctive tone. COM calls to shared secondary extensions can be answered by anyone in the group.

### To establish an intercom call:

1. Press the **Features** soft key to open the Features menu.
2. Scroll to the **Com** option and press **OK**. The dialtone plays.
3. Enter an extension for the Intercom call in the Dialing Keypad. The extension rings, overriding the forwarding feature setup.

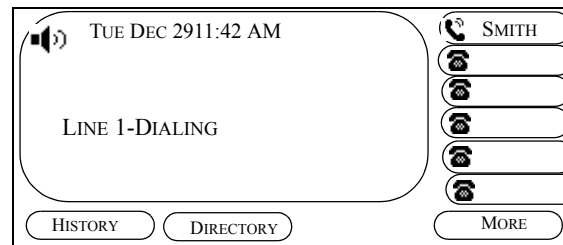

**Intercom (COM) calling Screen**

### To place Callback or Call Waiting on a “Forwarded” extension using COM calling:

1. Hang up after reaching the ‘forwarded to’ destination.
2. Press the **COM** soft key, or dial the COM calling access code, followed by the extension. Hear a busy tone or ringback.

3. Do one of the following:
  - Dial the Callback access code (2) while hearing a busy tone or ringback
  - Dial the Call Waiting access code (8) while hearing a busy tone

**LINE KEY LABELS**

The first six feature/shared keys on the phone can be labeled via soft labels as follows:

**To configure soft labels on the first six feature/shared keys:**

1. Press the **Menu** soft key. The Main Menu opens.
2. Scroll to the **Line Key Labels** option and press OK. The Line Key Labels page appears.

4. Press the **Save** soft key. The 'Settings Changed: Save and Reboot?' screen appears.
5. Press the **Save** soft key again. The phone reboots and the new label appears on the LCD screen.

**Related topics:** Answering calls, Hold, Dial

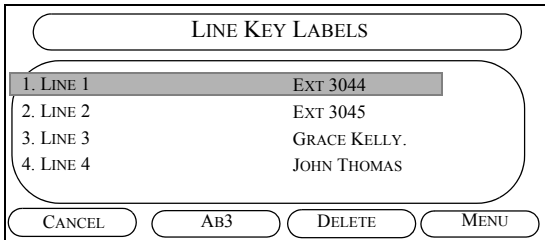

**Line Key Labels Screen**

3. Scroll to the desired label position (1,2 or 3) and use the *Ab3/123/ABC/abc* soft keys to enter an alphanumeric label for the line key.

## MENU

The **Menu** soft key provides access to the following features:

- **Ring Tones** - change ring sounds
- **System Information** - view info about the phone
- **Modify Settings** - *System Administrator use only*
- **Line Key Labels** - add soft labels to the first six feature/shared keys
- **Erase Data** - *System Administrator use only*

To access the Main Menu, press the **Menu** soft key.

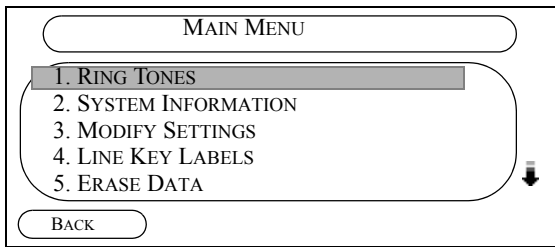

**Main Menu Screen**

### To access a Feature in the Main Menu:

1. Scroll to a desired feature in the Main Menu and press **OK**.
2. See the instructions on using the feature in this chapter.

**Related topics:** Contact List, Speed Dial

**MUTE**

The Mute feature allows you to put a caller on a one-way hold; you can still hear them, but they cannot hear you.

**To mute a call:**

- 1. While in conversation:
- 2. Press the **MUTE** key. The call is muted and the MUTE icon and text appear on the main screen.

**To remove mute:**

- 3. Press the **Mute** key again. The caller is removed from mute and can hear you again.

**Related topics:** Answering calls, Hold

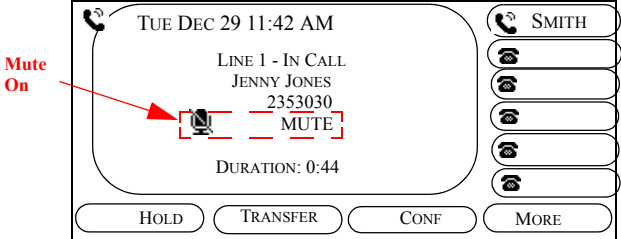

**Mute On Screen**

**NAVIGATE**

The **Navigate** keys (Up, Down, Left, and Right) allow you to scroll through LCD screens with multiple pages (indicated by arrows):

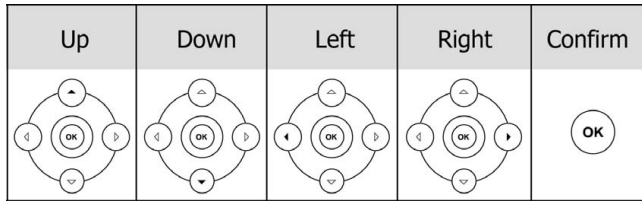

**Navigation Arrow Keys**

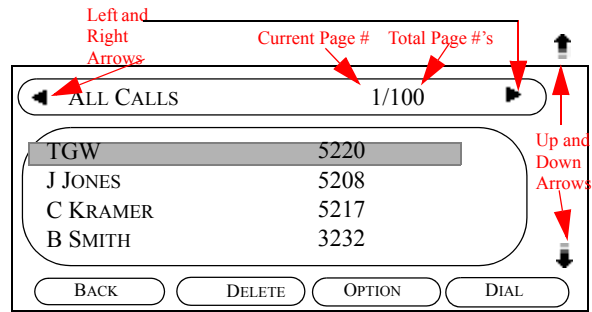

**History Screen, Page 1 of 100**

**Related topics:** Answering calls, Speakerphone, Headset

**PAGE**

The Page feature connects you to one of the pre-configured zones in order to announce a page. See your System Administrator for details on the zones configured for your system. Note that the number of zones available depends on the paging system used.

Use this form to note the page zones configured for your system.:

Zone	Area Description
1	typically used for 'all zones'
2	
3	
4	
5	
6	
7	
8	

**To make a page:**

1. Press the **Features** soft key. The Features screen appears.

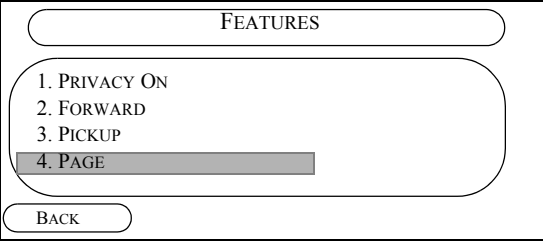

**Call Services LCD Screen**

2. Scroll to the **Page** option and press **OK**. The Enter Zone prompt appears.

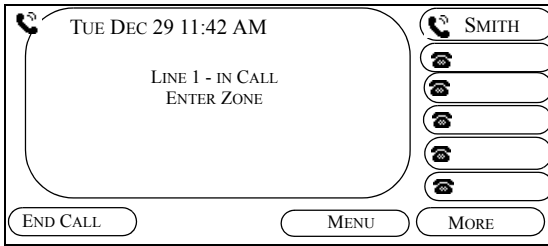

**Enter Zone screen**

3. Enter the number of the zone you wish to page on the Dialing Keypad.
4. Announce your page. The page is made for the selected zone.

**Related topics:** Answering calls, Speakerphone, Headset



**PARK**

The Park feature allows you to transfer or park a call at an extension without ringing that extension, while not interfering with the operation of that extension.

**To use Park:**

See your System Administrator to set up the Park feature for your phone.

1. While on a call:

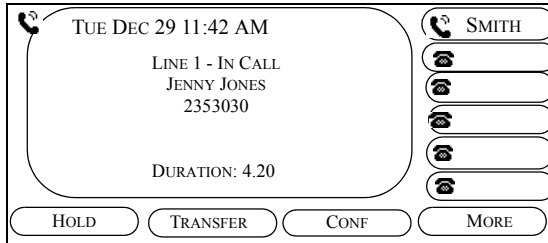

2. Press the **More** soft key.
3. Press the **Park** soft key.

4. Enter the extension to park the call at. The call is parked at that extension.

**NOTE:** See *PARK PICKUP* on page 60 for details on how to pick up a parked call.

**Related topics:** Park Pickup (Group and Directed), Answering Calls

**PARK PICKUP**

The Park Pickup feature allows you to pick up a parked call at your or another extension.

**To pick up a parked call on your extension:**

1. Go to any phone on the system.
2. Press the **Features** soft key. The Features Menu

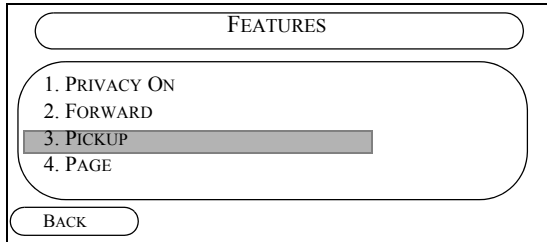

appears.

3. Scroll to the **Pickup** option and press **OK**. The Pick Up Call page appears and the dial tone plays.

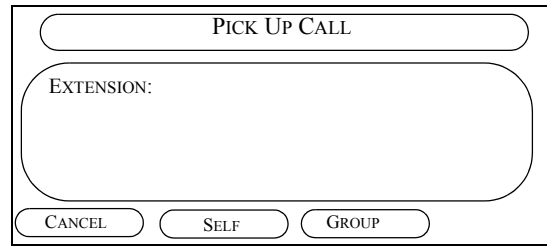

4. Do one of the following:
  - Enter the extension you wish to pick up a parked call from using the Dialing Keypad
  - Press the **Self** soft key to pick up the call at your extension
5. The parked call is transferred to the designated extension and you or the individual answering the call may start speaking to the caller.

**Related topics:** Answering calls, Speakerphone, Headset, Park, Pickup (Group and Directed)

**PICKUP (Group and Directed)**

**Directed Call Pickup:**

A Directed Call Pickup lets you answer another ringing extension from your phone.

To Pickup a ringing, parked, or camped on call:

- 1. From your phone:
- 2. Press the **Features** soft key.

The Features Menu appears..

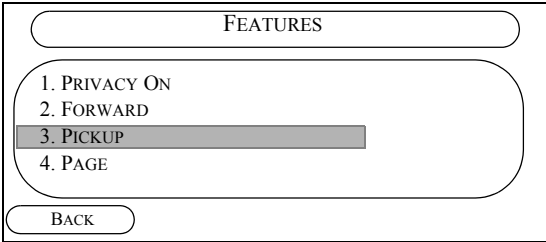

- 3. Scroll to the **Pickup** option and press **OK**. The Pick Up Call page appears and the dial tone plays.

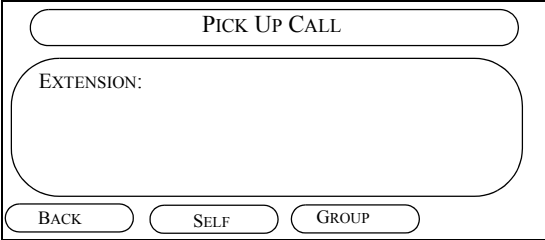

- 4. Enter the ringing, parked, or camped on extension number.
- 5. Start speaking to the caller.

**Group Call Pickup:**

A Group Call Pickup allows you to pickup a ringing extension without dialing the extension number, provided the extension is in your pickup group.

To Pickup a ringing call within your pickup group:

1. From your phone:
2. Press the **Features** soft key.

The Features Menu appears..

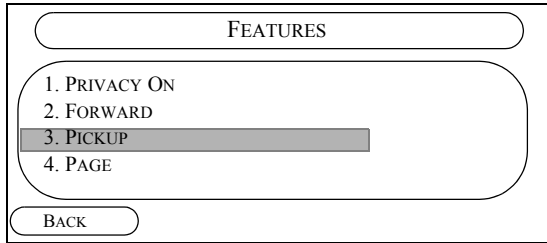

3. Scroll to the **Pickup** option and press **OK**. The Pick Up Call page appears and the dial tone plays.

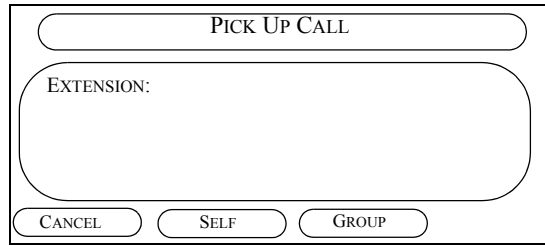

4. Do one of the following:
  - Press the **GROUP** LCD key to answer a call ringing at another extension in your Pickup Group. If more than one extension in your Pickup Group is ringing, you will be connected to the call that arrived first.
  - Enter the extension number of the phone you wish to answer the ringing call from.
5. Start speaking to the caller.

**Related topics:** Answering calls, Speakerphone, Headset, Park, Park Pickup

**PRIVACY**

The Privacy feature allows you to place your telephone in a temporary 'busy' condition to prevent incoming calls. Callers to your extension will hear a busy tone. Outgoing calls are unaffected, but incoming calls will hear a busy signal or are transferred to Voice Mail.

**To toggle the Privacy feature:**

- 1. Press the **Features** soft key to display the Features menu:

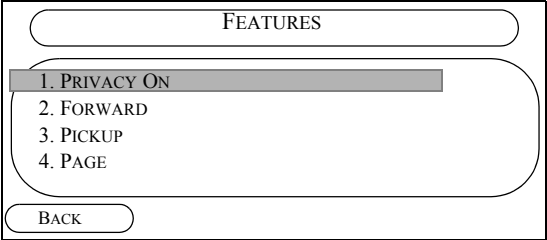

**Features Screen**

- 2. Scroll to the **Privacy On** or **Off** option and press **OK** to toggle it on or off. When Privacy is on, and the Privacy icon (DND) appears on the main screen when Privacy is on.

**Privacy On Indicator - DND or Do Not Disturb**

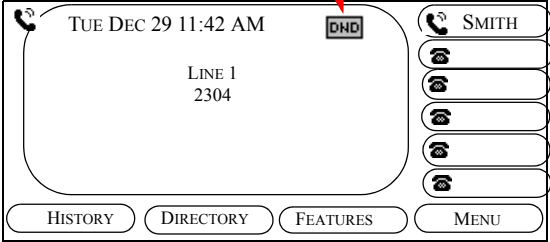

**Features Screen**

**Related topics:** Answering calls, Speakerphone, Headset

## REDIAL

The Redial feature allows you to quickly redial any of the previous calls you have made.

If the Redial feature is disabled, the **RD** key will still function, but the last number dialed will not be saved to the Call History. This is a security feature so that if you use a Security Code to dial out, it cannot be accessed by another person through your history.

To toggle the Redial feature on or off, see page 65.

### To redial a call:

Press the **RD** (Redial) key.

The REDIAL LCD menu appears, and the last number dialed is redialed:

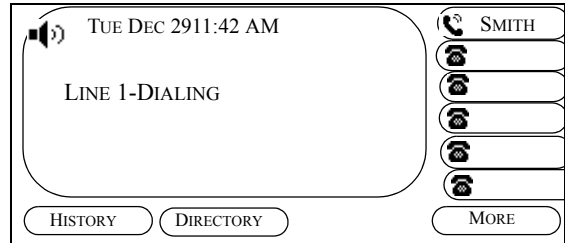

**Redial Screen**

**To toggle the Redial feature on and off:**

1. Press the **Menu** soft key. The Main Menu screen appears.
2. Scroll to the **Modify Settings** option and press **OK**.

The System Settings menu appears.

3. Scroll to the **Phone Settings** option and press **OK**.

The Phone Settings menu appears.

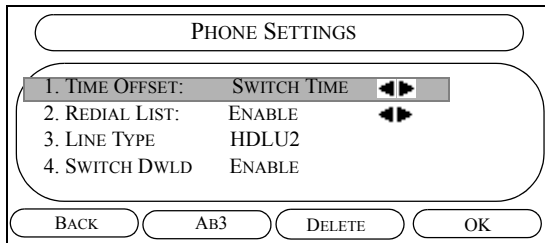

**Phone Settings screen**

4. Scroll to the **Redial List** option and press the left or right Navigate key to toggle the feature to enable/disable.

5. Press the **OK** soft key.

The System Settings menu reappears.

6. Press the **Save** soft key.

The "Settings Changed: Save and Reboot?" question appears.

7. Press the **Save** soft key.

The phone reboots and the Redial feature is now enabled/disabled.

**Related topics:** Answering calls, Speakerphone, Headset

**RING TONES**

The Ring Tone feature allows you to customize the ring sound that calls make when they come in.

The Ring Tones screen appears.

**To customize the Ring Tone:**

1. From the main screen, press the **Menu** soft key. The Main Menu screen appears:

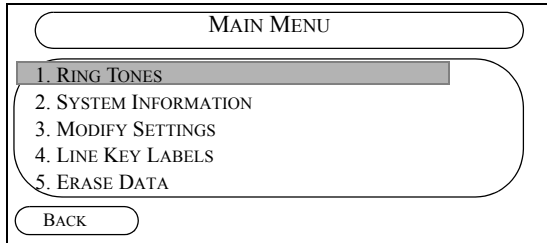

**Main Menu screen**

2. Scroll to the **Ring Tones** option and press OK.

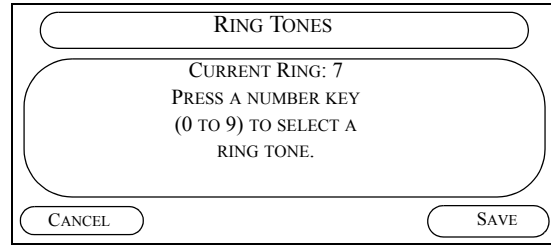

**Select Ring Tones screen**

3. Press a number key (0 to 9) on the Dialing Keypad to test the associated ring sound. The number appears as the Current Ring.
4. Press the **Save** soft key to save the current ring.

**Related topics:** Answering calls, Speakerphone, Headset



## SPEAKERPHONE

The speakerphone feature allows you to use the built-in speakerphone on the Arcata 28xx CIP-D instead of the handset or headset.

To dial a call using the speakerphone, with the handset onhook, dial the desired number on the Dialing Keypad.

To toggle from the handset to the speakerphone as needed, press the speakerphone key.

**Note** To change the volume on the speakerphone, see the *VOLUME* section on page 75.

**Related topics:** Answering calls, Speakerphone, Headset

**SPEED DIAL**

The Speed Dial feature allows you configure up to 10 frequently dialed numbers.

**Note** To quickly open the Speed Dial List, press the OK key.

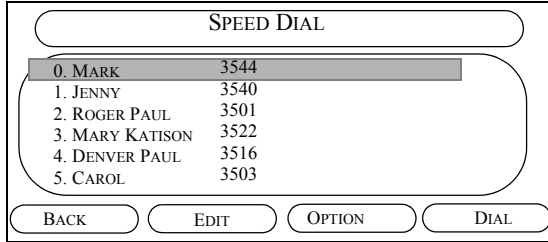

**Speed Dial LCD screen**

**To dial a speed dial call:**

1. Do one of the following to open the Speed Dial List:

- Press the **OK** key

or

- Press the **Directory** soft key to open the Directory Menu, then scroll to the Speed Dial option and press **OK**.

The Speed Dial List opens.

2. Scroll to the entry you wish to dial and press the **OK** key.

The number is dialed.

**To add or edit a speed dial entry:**

1. From the Speed Dial List screen, press the **Edit** soft key. The record for the selected option opens.

The screenshot shows a rectangular LCD screen. At the top, the name 'JENNY' is displayed in a rounded rectangular field. Below this, there are two rows of text: '1. NAME: JENNY' and '2. NUMBER: 3540'. At the bottom of the screen, there are four soft keys: 'CANCEL', 'AB3', 'DELETE', and 'SAVE', each in its own rounded rectangular button.

**Speed Dial LCD screen**

2. Press the **Ab3** soft key to scroll to the ABC soft key and use the Dialing Keypad to enter or edit the Name for the record.
3. Scroll to the **Number** option.
4. Press the **ABC** soft key to scroll to the **123** soft key, then use the Dialing Keypad to enter or edit the number for the record.
5. Press the **Save** soft key.

**To Copy a Speed Dial entry to the Contacts List:**

1. From the Speed Dial List, scroll to the desired caller to copy to the Speed Dial List, then press the Option soft key.
2. Scroll to the **Add to Contacts** option and press OK. The entry is added to the Contacts List.

**To delete a Speed Dial record:**

1. From the Speed Dial List, scroll to the desired contact.
2. Press the **Option** soft key.
3. Scroll to the **Delete** option and press OK. The record is removed from the Speed Dial List.

**Related topics:** Answering calls, Speakerphone, Headset

### TIME AND DATE

The current time and date is displayed on the main screen, as shown below. The time and date are automatically set.

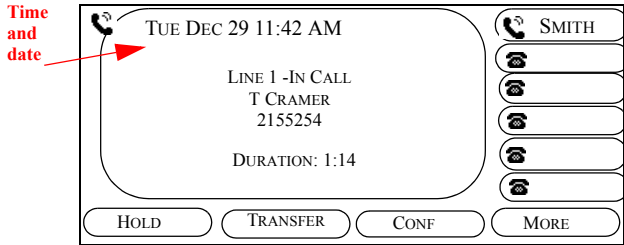

## TRANSFER

The Transfer feature allows you transfer the current call to another extension.

### To transfer a call:

1. While on a call:

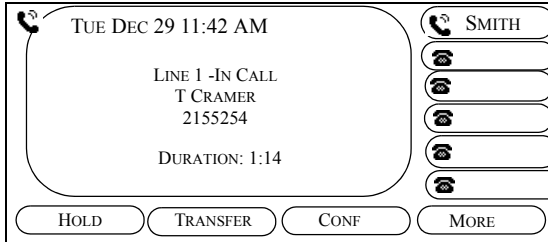

**In Conversation LCD Screen**

2. Press the **Transfer** soft key. The first party is put on hold as you hear dial tone.
3. Dial the extension to transfer the call to on the Dialing Keypad.

4. Do one of the following:

- **Unsupervised Transfer:** Listen for ringback, then, hang up to complete the transfer
- **Supervised Transfer:** When the second party answers, announce the call transfer, then hang up to complete the transfer.

**Related topics:** Forward, Park, Conference

## VIEW EXTENSION

You can check the status of any extension on the network, including your own.

The View Extension page appears:

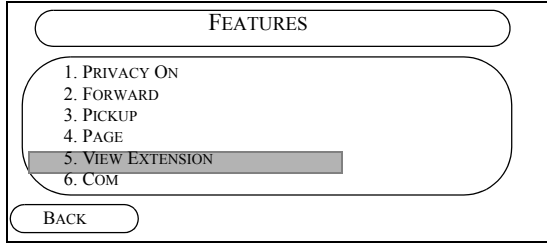

Features LCD Screen

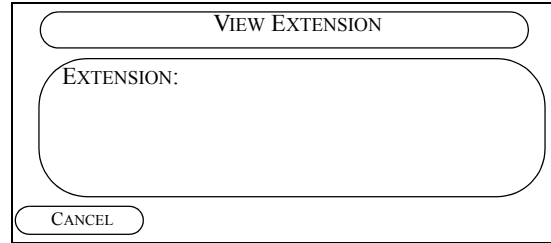

View Extension Screen

### To check the status of an extension:

1. Press the **Features** soft key.
2. Scroll down to **View Extension** and press OK.

- 3. Enter the extension you wish to check on the Dialing Keypad. The status is displayed (idle, busy, etc.) **Note:** 'F' indicates the extension has been forwarded.

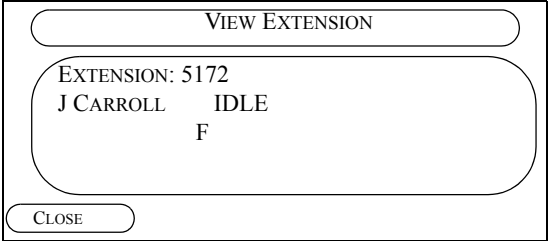

**Status of Ext 5172 Screen**

## VOICE MAIL

The Voice Mail feature allows you to receive calls to a message box when you are away from your phone, and retrieve the recorded message later on.

The Voice Mail Message LED flashes green when there is new voice mail in your message box.

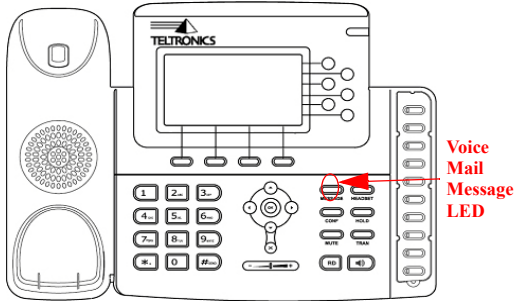

### To retrieve voice mail messages:

1. When the Voice Mail Message LED flashes green:
2. Press the **MESSAGE** key.
3. Enter your Voice Mail Password on the dialing keypad at the voice prompt.
4. Follow the voice instructions to record a greeting and check your voice messages.

**Note** To retrieve you voice mail when away from your phone, see the System Administrator for details.

**Related topics:** Answering calls, Speakerphone, Headset



## VOLUME

The volume on the Arcata 28xx CIP-D can be toggled up or down for voice, headset, ringer or speakerphone.

The Arcata 28xx CIP-D is hearing aid compatible and offers 15 volume levels to select from.

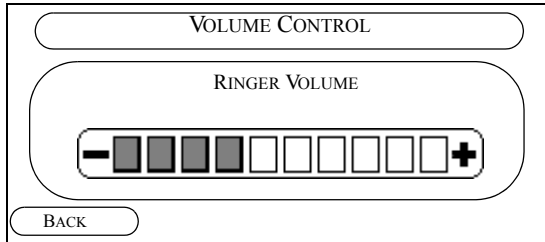

- speakerphone - with the **SPEAKERPHONE** key pressed
  - ringer - when the handset is on hook
2. Press the **VOLUME** button to increment/decrement the volume level, as follows:
    - To increase the volume, press the plus sign to the right on the Volume button
    - To decrease the volume, press the minus sign to the left on the Volume button

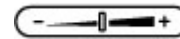

### To change the Cerato phone's volume level:

1. For each of the following scenarios (either on a call or not):
  - handset - when the handset is off hook
  - headset - with the **HEADSET** key pressed

**Related topics:** Answering calls, Speakerphone, Headset

## WEB CONFIGURATION

The Web Interface page opens.

**NOTE:** Web Configuration is not supported for a 2826 phone configured as a digital endpoint.

Typically, the Arcata 28xx CIP-D is configured by the system administrator during initial installation and setup. The phone can also be configured via the Internet, and is a quick way to enter speed dial and directory entries.

To configure the phone via the Internet:

1. Enter the IP address of your phone in Internet Explorer.

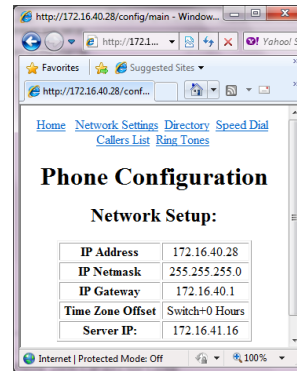

2. Select the field links (i.e., Network Settings, Directory, Speed Dial, Callers List, Ring Tones) to open each area for the phone and configure the settings.

## TROUBLESHOOTING

This chapter gives solutions to problems you may encounter while operating the Arcata 28xx CIP-D. Contact your system administrator for problems not referred to here.

### PROBLEM/SOLUTION

#### Blank screen

- Check the AC adapter. Verify that the adapter is not damaged and that it is securely plugged into a working electrical outlet.
- Verify that the ethernet cable is securely attached to the Arcata 28xx CIP-D.

#### No dial tone

- Check the AC adapter. Verify that the adapter is not damaged and that it is securely plugged into a working outlet.
- Verify that the ethernet cable is

securely attached to the Arcata 28xx CIP-D.

- Unplug AC adapter and plug it back in to reset the Arcata 28xx CIP-D.
- Check with the administrator/service provider to make sure the Arcata 28xx CIP-D is provisioned correctly.

#### Arcata 28xx CIP-D does not ring

- Check the ringer volume.
- Verify that the ethernet cable is securely attached to the Arcata 28xx CIP-D.
- Check with the administrator/service provider to make sure the Arcata 28xx CIP-D is provisioned correctly.

#### Handset does not work

- Check the handset volume. See *VOLUME section* on page 75.

---

**Speakerphone does not work**

- Check that the speakerphone light is lit when **SPEAKER** is pressed.
- Check the Speakerphone volume. See *VOLUME* section on page 75.

**Headset does not work**

- Verify the headset is securely plugged into the headset jack.
- Check that the headset light is lit when **HEADSET** is pressed.
- Check the Headset volume. See *VOLUME* section on page 75.

**Phone appears to be locked**

- Force reboot by unplugging the AC adaptor. All LEDs will light up and the LCD will blank out for approximately one minute before reestablishing communication with the Cerato.

**Line 2 or 3 lock up**

- The Cerato is not set up properly for

the circuit. Contact your system administrator.

**Line 1 doesn't hang up**

- The Cerato is not set up properly for the circuit. Contact your system administrator.

**LCD menu displays the wrong date or time**

- The time zone offset is probably wrong for your location. Contact your system administrator.

**The View Extension Forward indicator 'F' displays without Forward options set**

- There may be some CRG 1 forwards set in the switch for your primary extension and your SKEY extension for roll-over purposes and Voicemail.

---

### **Daisy-chaining IP phones**

- Do not connect an IP phone to another IP phone through the access port. Each IP phone should directly connect to a switch port.

If you connect IP phones together in a line (daisy-chaining), a problem with one phone can affect all subsequent phones in the line. Also, all phones on the line share bandwidth.

### **Moving a network connection from the phone to a workstation**

- If you are powering your phone through the network connection, you must be careful if you decide to unplug the phone's network connection and plug the cable into a desktop computer.

The computer's network card cannot receive power through the

network connection; if power comes through the connection, the network card can be destroyed. To prevent this, follow the instructions of manufacture of in-line power provider.

Several seconds of being disconnected may be required for the device to recognize that there is no longer a phone on the line, and to stop providing power to the cable.

### **Changing the telephone configuration**

- Only an administrator should change the phone configuration. Incorrectly changing parameters will result in the phone not Duplicate IP screen
- There may be another device on the network with your phone's IP address. Change the IP address.

---

### **DHCP Not Working**

- Contact Network Administrator.

### **A 2826 phone configured as a digital endpoint will not connect to the Cerato System**

- Verify that the digital firmware version (ccdigi.rom) is loaded on the phone.
- Verify that the **Feature Class** setting on the phone has **Extension status inquiry** set to *YES*.
- Verify that you are using the RJ11-to-RJ45 cable and that it is connected to the phone's PC port and not the Internet port.

## VIEWING PHONE SETTINGS

The Arcata 28xx CIP-D should be configured by the system administrator during initial installation and setup. The phone settings can be viewed at any time as described in this chapter.

System information is viewed via LCD menus which are accessed from the Main Menu LCD screen. Note that you can only view this information and cannot attempt to change any of the settings. Contact your system administrator if you need changes or have questions.

1. To view the settings for your phone, press the **Menu** soft key. T

The Main Menu appears.

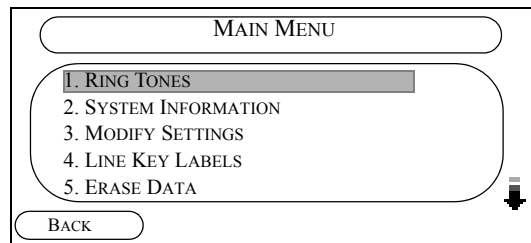

**Main Menu LCD Screen**

**NOTE:** The **Modify Settings** and the **Erase Data** options are used by the system administrator only. See *RING TONES* in Chapter 2 for details on customizing the ring sound that a phone makes when calls come in.

2. To view information about the system, scroll to the System Information option, and press OK.

The System Information page appears.

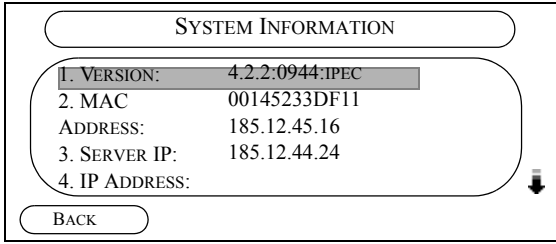

**System Information LCD Screen - Page 1**

3. Scroll down using the Navigation arrows to view additional pages, as needed.

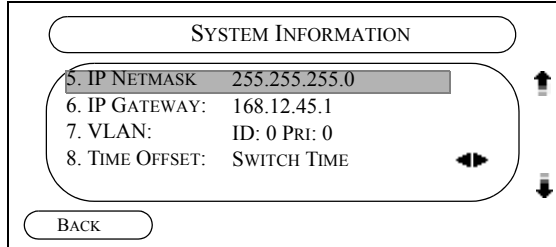

**System Information LCD Screen - Page 2**

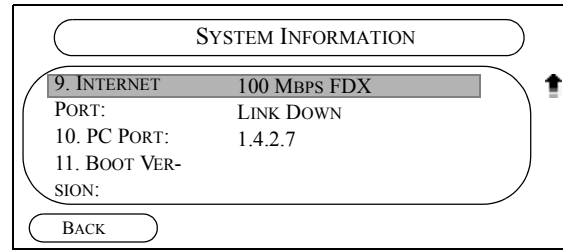

**System Information Screen Page 3**

4. Use Table 2-A for a description of the settings.

Table 2-A. System Information Settings

Name	Description
Version	Current software version loaded
MAC Address	MAC address of the phone - located on the back label
Server IP	Address of the gateway supporting the phone
IP Address	IP address assigned to the phone
IP Netmask	The IP subnet mask for the phone



Table 2-A. System Information Settings

Name	Description
IP Gateway	The IP gateway for the phone
VLAN	Settings for prioritizing data and voice
Time Offset	Time offset from the Cerato system clock, use arrow keys to select time in 30 minute increments
Internet Port	The current status of the Internet Port (located on the back of the Arcata 28xx CIP-D), which can be one of the following: <ul style="list-style-type: none"> <li>• 100 MBPS FDX</li> <li>• 10 MBPS FDX</li> <li>• 100 MBPS HDX</li> <li>• 10 MBPS HDX</li> <li>• Link Down</li> </ul>

Table 2-A. System Information Settings

Name	Description
PC Port	The current status of the PC Ethernet Port (located on the back of the Arcata 28xx CIP-D), which can be one of the following: <ul style="list-style-type: none"> <li>• 100 MBPS FDX</li> <li>• 10 MBPS FDX</li> <li>• 100 MBPS HDX</li> <li>• 10 MBPS HDX</li> <li>• Link Down</li> </ul>
Boot Ver	Boot loader version

---

This page intentionally blank.

# FCC REQUIREMENTS

## *FCC PART 15 INFORMATION*

This equipment complies with Part 15 of the FCC rules. Operation is subject to the following two conditions: (1) This device may not cause harmful interference, and (2) this device must accept any interference received, including interference that may cause undesired operation.

This equipment has been tested and found to comply within the limits for a Class B digital device, pursuant to Part 15 of the FCC Rules. These limits provide reasonable protection against harmful interference in a residential installation.

This equipment generates, uses and can radiate radio frequency energy. If not installed and used in accordance with the instructions, the equipment might cause harmful interference to radio communications. However, there is no guarantee that interference will not occur in a particular installation.

If this equipment does cause harmful interference to radio or television reception, which can be determined by turning the equipment off and on, the user is encouraged to try to correct the interference by one or more of the following measures:

- Reorient or relocate the receiving antenna.
- Increase the separation between the equipment and receiver.
- Connect the equipment into an outlet on a circuit different

from that to which the receiver is connected.

Consult the dealer or an experienced radio/TV technician for help.

**Changes or modification to this device not expressly approved by Teltronics could void the user's authority to operate this equipment.**

## **WARRANTY**

If your telephone is defective in material or workmanship and you return it within one year from the date of purchase, we will repair it, or, at our option, we will replace it. If we repair it, we might use reconditioned replacement parts or materials. If we choose to replace it, we might substitute an identical reconditioned unit. The repaired/replaced unit is warranted for either (a) ninety days, or (b) the remainder of your phone's original one year warranty, whichever is longer.

### ***WHAT THIS WARRANTY DOES NOT COVER***

This warranty does not cover defects resulting from accidents, alterations, failure to follow this manual's instructions, battery leakage, misuse, fire, flood, and Acts of God.

## FCC REQUIREMENTS

---

We do not warrant this product to be compatible with party lines, with all types of telephone equipment, or with your specific customer premises equipment. Shipping costs to and from authorized service centers are not covered.

We are not responsible for implied warranties, including those of fitness for a particular purpose and merchantability after the initial one year period. We do not pay for loss of time, inconvenience, loss of use of the product, or property damage caused by this product or its failure to work, telephone company service calls, or any other incidental or consequential damages.

### ***STATE LAW RIGHTS***

Some states do not allow limitations on how long an implied warranty lasts, or the exclusion of limitation of incidental or consequential damages, so the above exclusions might not apply to you. This warranty gives you specific rights; you may also have other rights, which can vary from state to state.

## ACCESS CODES AND AUDIBLE

This section gives tables that list the following:

- access codes used with some features
- audible tones you will hear when using your phone

---

## Access Codes

The following table lists the Access Codes used to operate the named features of the Arcata 28xx CIP-D.

See your System Administrator to get the access codes for your system and fill them in next to their respective features in the table and in the code fields throughout this user guide.

Access Code	Description
	outside line (typically '9')
	appointment reminder <ul style="list-style-type: none"><li>• setup</li><li>• cancel</li><li>• remote setup</li><li>• remote cancel</li></ul>
2	callback (station & trunk)
	account code calling
	pick up

---

## Audible Tones

Tones you hear when using your telephone indicate the status of your call or the feature you are initiating. For example, while initiating Call Forwarding you will hear Confirmation Tone after successful completion of each step.



**Dial Tone.** What you hear when you pick up your handset. Ready for dialing internal numbers or feature access codes. (You also hear this tone when you dial an outside line access code.)

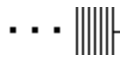

3 beeps, hmmm...

**Confirmation Tone.** What you hear after successfully initiating a feature. It may be followed by dial tone for further dialing.



bzt, bzt, bzt, ...

**Busy Tone.** What you hear after dialing an extension that is in an off-hook condition.



3 hums, humm...

**Stutter Dial Tone.** What you hear after successful completion of hookflash with one party on hold. Ready for further internal dialing.



00000...

**Feature Dial Tone.** What you hear after successful completion of hookflash with two parties on hold. Ready for further internal dialing.



arr-e, arrr-ee,...

**Error Tone.** What you hear when you make a mistake in dialing (i.e. time-out occurs, the dialed extension number is nonexistent, or you have accessed a disallowed feature).



tick, tick, tick,...

**Hold Tone.** What you hear (instead of music) when your phone has been placed on hold.



musical scale

**Queue Prompt Tone.** What you hear when you reach an all-trunks busy condition and you are allowed to enter On-Hook Queuing.

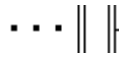

3 beeps, ticking...

**Off-Hook Queue Tone.** What you hear when you reach an all-trunks busy condition and you are allowed to enter Off-Hook Queuing.



extended beep

**Paging Beep.** What you hear just before the system allows your page announcement. After the beep, you hear no tone (silence) so you can page.



repeating tones

**Extension Security Tone.** What the party trying to dial into a secure phone hears.



3 tones, 3 times

**Message Waiting Tone.** What you hear if you initiate dialing when you have a message waiting.



## INDEX

### A

access codes 88  
account code calling access code 88  
answering calls 29  
appointment reminder 31  
appointment reminder access code 88  
audible tones 89  
Automatic Idle Line Selection 30  
Automatic Ringing Line Selection 30

### B

back LCD key 12  
Blank screen 77

### C

callback 33  
callback access code 88  
callers' list 35, 37, 47  
cancel 35

cancel LCD key 12  
Cleaning the unit xix  
COM calling 51  
conference 36  
contact list 27, 37

### D

dial 40  
Dial tone missing 77  
DIRECTORY 42  
directory 37, 42  
Disposal of product xx

### F

FCC information 85  
feature access codes 88  
features 43  
forward 44

**H**

hang up 35  
headset 46  
hold 50

**I**

Intercom (COM) calling 51

**L**

LCD  
    accessing menus 11  
    navigation 12  
    purpose 11  
LCD operation 10  
line key labels 27, 53

**M**

MENU 54  
menus  
    LCD 11  
mute 55

**N**

NAVIGATE 56  
navigate key 11  
navigating the LCD 12

**O**

operating the LCD 10  
outside line access code 88

**P**

page 57  
park 59  
park pickup 60, 61  
phone settings  
    viewing 81  
pick up access code 88  
privacy 63

**R**

redial 64, 65  
ring tones 27, 66

---

Ringer 77, 78

**S**

safety instructions xix  
save LCD key 12  
speakerphone 67, 78  
speed dial 68  
system information  
viewing 82

**T**

time and date 70  
transfer 71  
troubleshooting 77

**U**

using the LCD 10

**V**

view extension 72  
viewing phone settings 81  
viewing system information 82

voice mail 74  
voice over company network 2  
voice over internet 2  
volume 75  
volume key 11

**W**

warranty 85





## **Teltronics Arcata 2826/2806 CIP-D User Guide**

© 2010 Teltronics, Inc.



Teltronics, Inc.  
2511 Corporate Way  
Palmetto, Florida 34221-8478 USA  
941.753.5000  
[www.teltronics.com](http://www.teltronics.com)

Part Number 610-0000-0847 Rev B